



P.A. - S.p.A. - EQUIPAGGIAMENTI TECNICI DEL LAVAGGIO

VIA MILANO, 13 - CASELLA POSTALE 115 - 42048 RUBIERA (REGGIO EMILIA) - ITALY
 Tel. +39 0522 623611 - Fax. +39 0522 629600 - R.E.A. RE 156319 - R. I. RE 11535 - Mecc. RE 013446
 C.F. e P. IVA 01035950359 - Cap. Soc. i.v. € 750.000,00 - Codice Identificativo C.E.E. IT 01035950359
 ART. 2497 - BIS C.C. DIREZIONE E COORDINAMENTO BENETTI srl R.I. TRIB. DI RE 01480690351
 http://www.pa-ell.it - E-mail: info@pa-ell.it



VB 140/160 Trapped pressure unloader valve



At gun closure, the water flow is discharged through the bypass, reducing the pressure in the system upstream of the valve.

Technical booklet: E 284



• **60.4800.00**

G3/4" F

- Valve suitable for use with big flow rates.
- Dynamic seals made up of O-ring and backup ring .
- Optimized internal passages that guarantee reduced pressure loss.
- O-rings of the fittings positioned upstream of the thread: no risk of fittings ejected in case of overpressure.
- Valve suitable for use with more than one gun at the same time.

TECHNICAL SPECIFICATIONS

Construction material		Brass body and internal parts in Sst.										
Rated temperature (1)		90°C – 195°F										
Nominal Size		DN 20 – NPS 3/4"										
PART NUMBER	RATED PRESSURE		PERMISSIBLE PRESSURE		MINIMUM ADJUSTABLE PRESSURE		% PRESSURE DECREASE FOR VALVE RESET (2)	MAXIMUM FLOW		WEIGHT		INLET OUTLET BYPASS
	bar	psi	bar	psi	bar	psi	%	l/min	USG pm	g	lbs	
60.4800.00	160	2300	180	2600	16	230	22	140	37	1830	4	G3/4" F

- 1) The valve has been designed for a continuous use with water at a temperature of **60°C (140°F)**. It can work for short periods with water at the maximum temperature of **90°C (195°F)**.
- 2) When the gun is closed (valve is in bypass mode), this is the decrease of pressure that has to occur in the circuit downstream of the valve, in order that the valve can restore the working pressure in the system. The indicated figure is expressed as a percentage of the pressure setting (working pressure).

At gun closure, a pressure increase occurs in the circuit downstream of the valve. This pressure increase is used to activate the valve and discharge all the flow in bypass. The value of the pressure increase cannot be calculated. It depends on the correct setting of the valve (see PRESSURE ADJUSTMENT/SETTING) and on the layout of the system: flow rate, working pressure, length and characteristic of the tubes, closing time of the gun.

DIMENSIONAL DRAWING

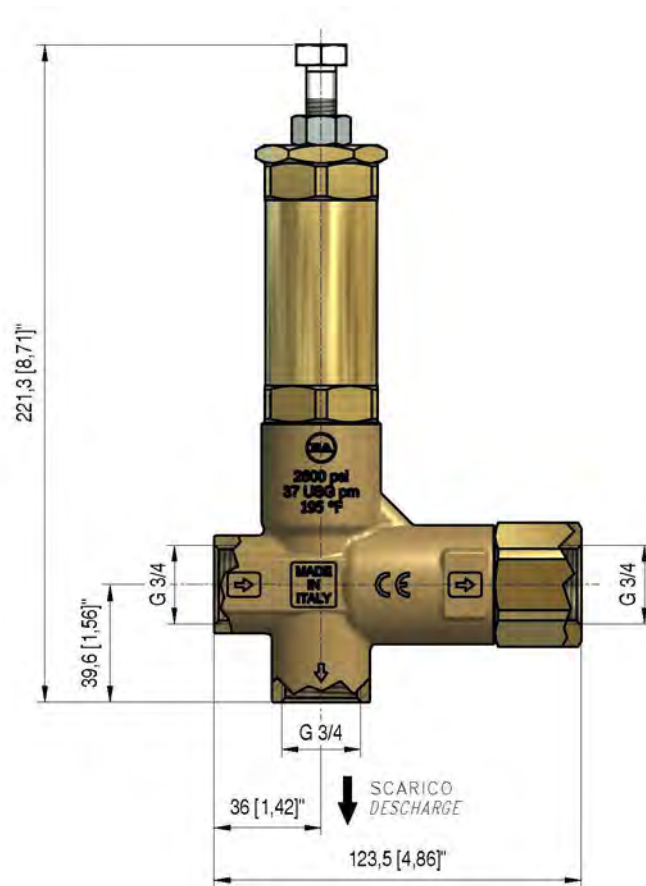

SELECTION

This product is to be utilized with clean fresh water, even slightly additivated with normal detergents. For use involving different or corrosive liquids, contact the PA Technical department. Appropriate filtration should be installed when using impure liquids. Choose the valve in line with the working data of the machine where to be installed (permissible pressure, maximum flow rate and rated temperature of the system). In any case, the pressure of the machine must not exceed the permissible pressure imprinted on the valve.

OPERATION

The valve regulates the pressure of the system by altering the flow discharged by the bypass. The adjustment is carried out by changing, by means of a piston, the position of a shutter that partially closes the bypass opening. At gun closure, a check valve closes and isolates the part of the circuit downstream of the valve: the pressure increase that remains trapped is used to activate the complete opening of bypass. All the flow supplied by the pump is therefore discharged at low pressure through the bypass and the pump works at low pressure.

INSTALLATION

This product is intended to be incorporated on a finished machine. On a system that produces hot water, this accessory must be fitted upstream of the heat generator. On a system that generates hot water, it is advisable to fit in accessories that limit the accidental increase of fluid temperature.

Always install a safety valve.

It is recommended to use a nozzle with a size that, at gun opened, allows to discharge from the valve bypass at least 5% of the flow supplied by the pump in order to obtain a constant pressure value, an easy adjustment and to avoid troublesome pressure spikes at gun closure.

If the nozzle wears out, the working pressure decreases. To reset the pressure back to work level, it is necessary to replace the worn out nozzle. When a new nozzle is fitted, re-setting of the system to its original working pressure is necessary.

DISCHARGE SYSTEM AND WATER ADDUCTION

We recommend to fit the valve with the bypass discharge returned into a tank. It is advisable that the tank be fitted with deflectors to reduce eventual turbulence and air bubbles, generated by the admission of the bypass flow, which could be harmful for the pump. With elevated flow or near to the maximum flow of the valve, the installation with a recirculation of bypass direct to the pump could cause potential pressure spikes harmful for the pump.

PRESSURE ADJUSTMENT/CALIBRATION

The desired working pressure must be adjusted with the system running and the gun opened. Adjust the pressure by screwing or unscrewing the adjustment screw. The operation is easier if the correct nozzle has been chosen (see paragraph "INSTALLATION"). When screwing the adjustment screw a consequent pressure increase must be matched. If, before reaching the desired pressure, there is no pressure increase when screwing the adjustment screw, do not insist but check the correct ratio nozzle/flow rate – pressure and, if necessary, fit a nozzle with an inferior size.

PROBLEMS AND SOLUTIONS

PROBLEMS	PROBABLE CAUSES	SOLUTIONS
Frequent valve recycles	Damaged check valve O-ring Leaking connections Restricted bypass or too small diameter of the bypass hose	Replace Check or renew Clean or adapt passage diameter
Valve does not reach the working pressure	Piston sealings worn out Material between seat and shutter Seat worn out Nozzle worn out Incorrect choice of nozzle	Replace Clean the seat Replace Replace Fit nozzle with lower size
High pressure peaks at gun closure	There is not a min of 5% of total flow discharged in bypass Excessive flow in bypass Adjustment with spring totally compressed	Reset correctly Change type of valve or adjust passages Loosen adjustment screw/knob and eventually fit nozzle with lower size
Valve does not discharge at low pressure at gun closure	Jammed check valve Material matter on check valve	Clean or replace Clean

MAINTENANCE

STANDARD: every 400 working hours, control and lubricate the seals with water resistant grease.

SPECIAL: every 800 working hours, control the wear of the seals and internal parts and, if necessary, replace with original PA parts taking care, during installation, to lubricate with water resistant grease.

Maintenance has to be carried out by specialized technicians.

The Manufacturer is not to be considered responsible for damage as a result from incorrect fitting and maintenance.

REGULATIONS : see Norm Manual.

The accessory hereby described bears the CE marking in accordance with the standards and directives published in the Declaration of Conformity.

For a correct utilization, follow the directions described in this manual and re-print them on the Use and Maintenance manual of the machine. If needed, ask for the original Conformity Declaration for the chosen accessory. The present manual is valid for all unloader valves named **VB 140/160**.

Technical data, descriptions and illustrations are indicative and liable to modification without notice.

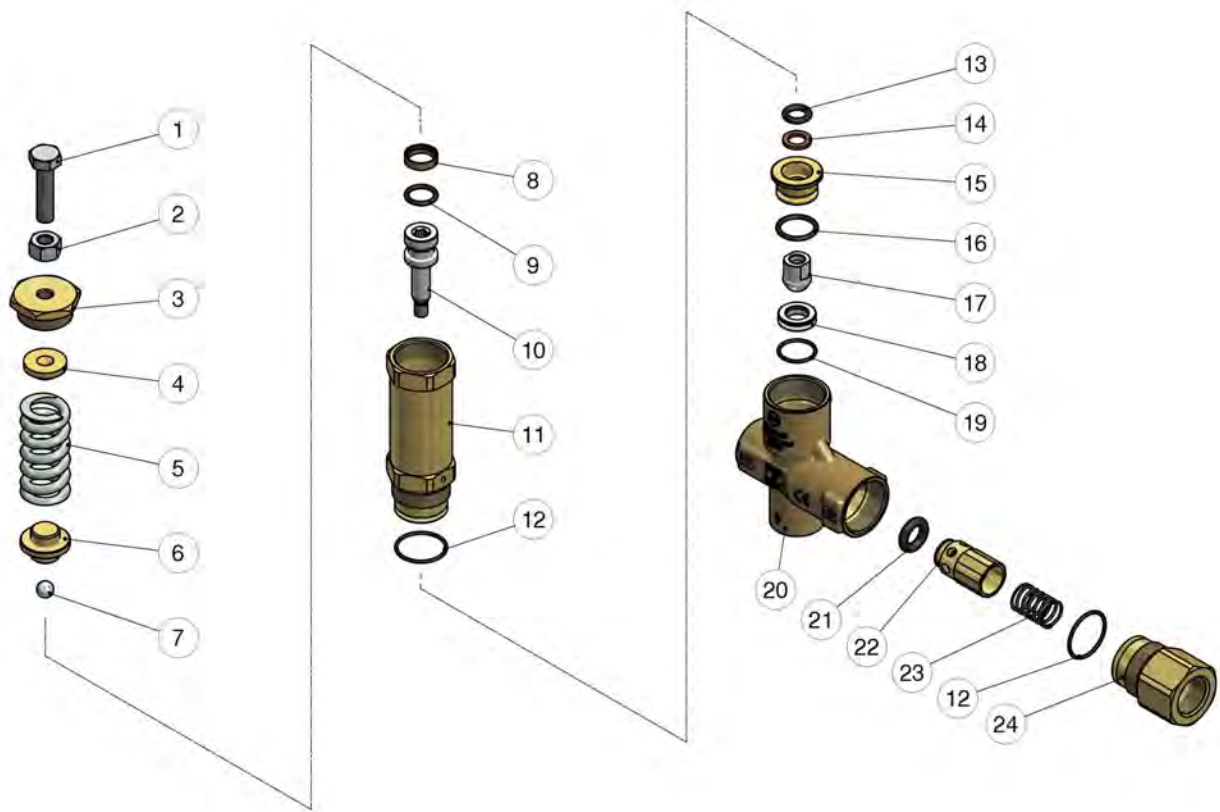

Pos.	P/N	Description	Q.ty	K1	K2	K3	K4	
1	60.5011.61	Valve regulating screw, M10x44 z.pl.	1					3
2	11.4629.00	Hex. nut, M10	1					10
3	60.5008.31	Upper plug, M10 brass	1					1
4	60.5007.31	Spring guide spacer, brass	1					3
5	60.5006.61	Spring, 6x30x62 mm	1					5
6	60.4304.31	Spring guide spacer, brass	1					2
7	14.7461.00	Ball, 13/32" Sst.	1					10
8	10.4094.00	Back-up ring, 15,5x20x5 mm	1	•				5
9	10.3180.00	O-ring, 2,62x15,08 mm	1	•				10
10	60.4803.51	Piston, M8 Sst.	1					2
11	60.4801.31	Piston holder, brass	1					2
12	10.3077.08	O-ring, 1,78x28,3 mm Ni 85	2	•				10
13	10.3234.00	O-ring, 3,53x10,69 mm	1	•				10

Pos.	P/N	Description	Q.ty	K1	K2	K3	K4	
14	10.4044.00	Back-up ring, 11 x 17,2 x 2 mm	1	•				10
15	60.4807.31	Reduction bushing, brass	1					2
16	10.3195.01	O-ring, 2,62x20,29 mm Ni 90	1	•				10
17	60.4806.51	Shutter pin, M8 Sst.	1	•				3
18	60.4804.51	Seat, 14x23x6 mm Sst.	1	•				2
19	10.3072.01	O-ring, 1,78x20,35 mm Ni 85	1	•				10
20	60.4805.35	Housing-VB140/160, 3/4 Bsp F brass (1)	1					1
20	60.4808.35	Housing-VB140/160, 3/4 Npt F brass	1					1
21	10.3314.00	O-ring, 5,33x12,06 mm	1	•				10
22	60.5012.99	Shutter pin, brass+or 5,33x12,06 mm N	1					2
23	60.5013.51	Spring, 1,3x18x29 mm Sst.	1					10
24	60.4802.31	Coupling, 3/4" Bsp F brass (1)	1					3
24	60.4809.31	Coupling, 3/4"Npt F brass	1					3

Kit	P/N	Description	Q.ty
K1	60.4812.24	Spares kit -VB140/160, 10x1pcs.	1

(1) 60.4800.50