

P.A. – S.p.A. – EQUIPAGGIAMENTI TECNICI DEL LAVAGGIO

VIA MILANO, 13 – CASELLA POSTALE 115 – 42048 RUBIERA (REGGIO EMILIA) – ITALY
 Tel. +39 0522 623611 – Fax. +39 0522 629600 – R.E.A. RE 156319 – R.I. RE11535 – Mecc. RE 013446
 C.F. e P. IVA 01035950359 – Cap. Soc. i.v. € 750.000,00 – Codice Identificativo C.E.E. IT 01035950359
 ART. 2497 – BIS C.C. DIREZIONE E COORDINAMENTO BENETTI srl R.I. TRIB. DI RE 01480690351
 Web: <http://www.pa-etl.it> – E-mail: info@pa-etl.it



VRP175 – Safety and pressure regulating valve

Technical manual: E 248

Compensated pressure regulating valve with double connection for inlet port.
 Regulates the bypass of the fluid with a minimum variation of the pressure.
 Suitable to be utilized as a safety valve.

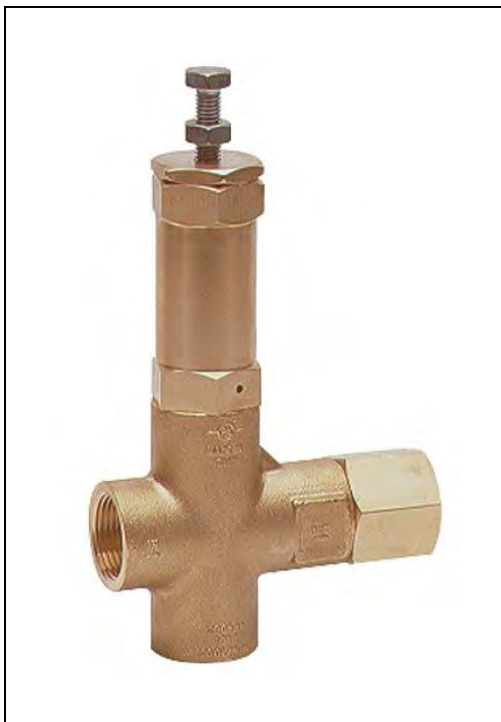
DN 15

- **60.0545.00** VRP175 G1/2 150 bar – 15 MPa

- Sturdy construction in Sst and brass.
- Piston return operated by strong springs for steady working and setting without faltering.
- Multiple connections for quick installation.

AS A SAFETY VALVE

- Reliable intervention discharging all the flow.
- Prompt and effective damping action against pressure spikes.

AS A PRESSURE REGULATING VALVE

- High balancing to guarantee slight variations of the rated pressure when the flow varies in bypass.
- Usable with a multiple number of lances.

TECHNICAL SPECIFICATIONS

Max. flow rate 200 l/min - Max. temperature 90°C (1)

Part number	Rated pressure	Permissible pressure	Minimum adjustable pressure	(2) Pressure increase as a VS – as a VRP		Inlet	Bypass	Weight
	bar - MPa	bar - MPa	bar - MPa	bar - MPa	- bar - MPa			
60.0545.00	150 - 15	170 - 17	15 - 1.5	18 - 1.8	- 7 - 0.7	G 1" F	G 1" F	2025

(1) The valve has been designed for a continuous use at a water temperature of 60°C. It can resist for short periods at a maximum temperature of 90°C.

(2) **Pressure increase** = is the increase of pressure needed into the valve for discharging the max. flow when utilized at rated pressure

Instruction manual, maintenance, installation, spare parts. For a correct utilization, follow the directions of this manual Re-print them on the use and maintenance booklet of the machine.	n. 12.9248.00
--	---------------

DIMENSIONAL DRAWING

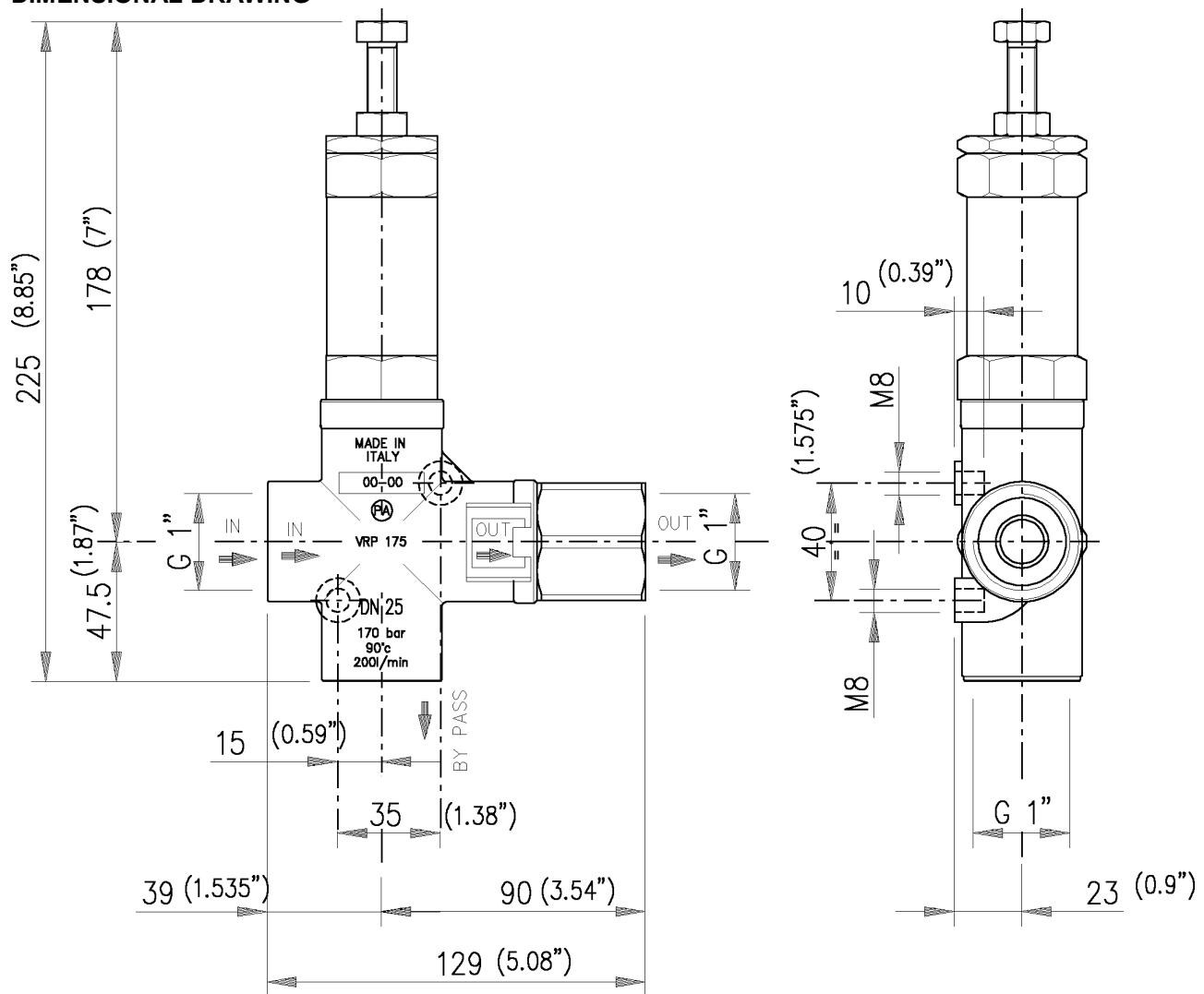

INSTRUCTIONS

SELECTION

This product is to be utilized with clean fresh water, even slightly additivated with normal detergents. For use involving different or corrosive liquids, contact the PA Technical department. Choose the valve in line with the data of nominal running (system rated pressure, max flow and max temperature). In any case, the pressure of the machine should not exceed the permissible pressure rate imprinted on the valve. When in use as pressure regulator, adopt a nozzle that allows a bypass of at least 5% of the total flow, bearing in mind that a worn out nozzle causes pressure loss. The valve, assembled in line with these indications, avoids pressure spikes whilst the machine is in operation.

INSTALLATION

This accessory, on a system that produces hot water, must be fitted **in front of the heat generator**.

As a SAFETY VALVE: in the case when frequently combined with unloader valves and low pressure in the pump, it has to be fitted in the section that remains pressurized when the gun is shut off.

As a PRESSURE REGULATOR: maintains the pressure in the system steady during flow changes. **Always** install with the correct specifications when combined with a safety valve. In case of discharge in the tank or directly into the pump, it is necessary to provide devices capable to prevent damaging turbulence to the liquid flow.

OPERATIONS

The discharge should be returned to a baffled tank. If, on the contrary, the pump is fed directly from the water mains, it is advisable to install a pressure reducing valve, before the pump, to avoid dangerous pressure spikes which could badly damage manifolds and suction valves. In case of extended conditions of bypass directed to the suction side of the pump, it is recommended to install a thermal valve (VT3 or VT6) to avoid dangerous water temperature build-up.

PRESSURE ADJUSTMENT/SETTING

As a SAFETY VALVE: the adjustment has to be made in such a way that the pressure setting is not superior to the system working pressure and its accessories; this prevents the arisal of numerous pressure increases in hot water systems and static pressure (gun shut off).

As a PRESSURE REGULATOR: adjust the valve when the system is pressurized and the gun open. The operation will be easy and smooth if the proper nozzle is chosen. When rotating the adjustment knob, it has to correspond to a consequent pressure increase; should the pressure stop increasing before reaching the desired value, **do not insist**, but check the correct nozzle size in relation to flow and pressure. On reaching the desired pressure, tighten the nut (pos 13) with a drop of paint in order to emphasize any tampering or slackness.

ATTENTION: The nut (pos 13) must never be removed otherwise a mechanical safety feature that limits the max pressure will lack , avoiding serious damage to persons and machine.

PROBLEMS AND SOLUTIONS

PROBLEMS	PROBABLE CAUSES	SOLUTIONS
Valve cycles	<ul style="list-style-type: none"> - Air inside the system - Worn out seals - Clogged circuit 	<ul style="list-style-type: none"> - Flush out - Replace - Clean or widen passages
The valve does not reach pressure	<ul style="list-style-type: none"> - Unproper nozzle size - Seat/shutter/ball worn out - Damaged nozzle - Impurities 	<ul style="list-style-type: none"> - Modify - Replace - Replace - Clean
Pressure drop	<ul style="list-style-type: none"> - Worn out nozzle - Pump gaskets worn out - Valve seat worn out - Air inside the system 	<ul style="list-style-type: none"> - Replace - Replace - Replace - Flush out
Pressure spikes	<ul style="list-style-type: none"> - There is not a min.5% of total flow in bypass - Clogged nozzle 	<ul style="list-style-type: none"> - Re-adjust - Clean - Repeat adjustment and replace nozzle
Water leakage from bypass Valve pounding	<ul style="list-style-type: none"> - O-ring seat damaged - Damaged seat - Impurities or worn out valve pumps 	<ul style="list-style-type: none"> - Replace - Replace - Clean

REGULATIONS : see norm manual

For a correct utilization, follow the directions described in this manual and re-print them on the Use and maintenance manual of the machine.

Make sure that you are given **the Original Conformity Declaration** for the accessory chosen. The present manual is valid for all unloader valves named **VRP 175**.

MAINTENANCE

Maintenance has to be carried out by **Specialized Technicians**.

STANDARD: every 400 working hours (circa 10,000 cycles), check and lubricate the seals with water resistant grease.

SPECIAL: every 800 working hours(circa 20,000 cycles), control the wear of the seals and internal parts and if necessary, replace with original PA parts taking care during installation and to lubricate with water resistant grease.

ATTENTION: reassemble the valve in the correct manner paying special attention how to set the valve as described in the paragraph **PRESSURE ADJUSTMENT/SETTING**.

The manufacturer is not to be considered responsible for damage as a result from incorrect fitting and maintenance

Technical data, descriptions and illustrations are indicative and liable to modification without notice.

60.0545.00 VRP 175 safety valv. 1"F Bsp

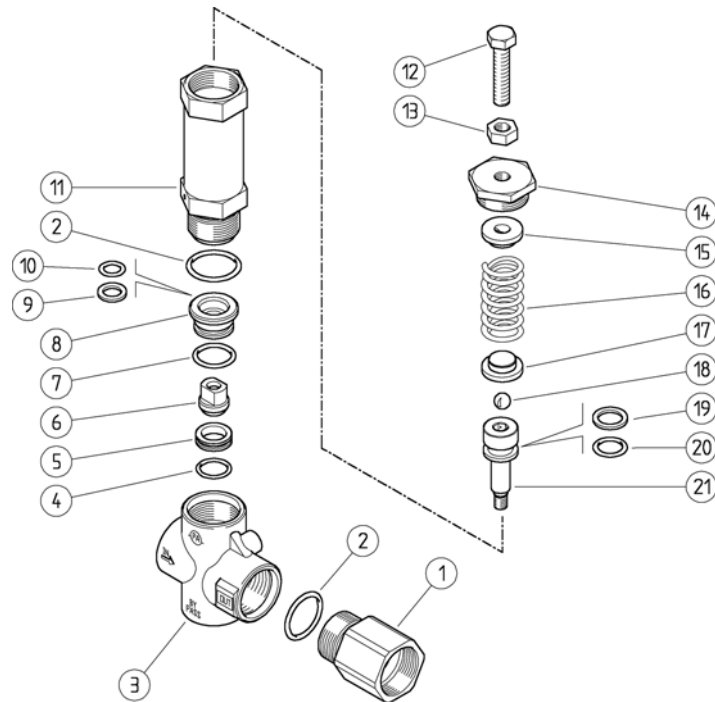

Pos.	P/N	Description	Q.ty	K1	K2	K3	K4	
1	60.5026.31	Coupling, 1"Bsp F brass	1					3
2	10.3206.01	O-ring, 2,62x28,25 mm	2	•				10
3	60.5024.35	Hous.-VB200/150-1"Bsp FF	1					1
4	10.3072.01	O-ring, 1,78x20,35 mm Ni 85	1	•				10
5	60.5002.51	Seat, 15,8x23x6 mm Sst.	1	•				2
6	60.5003.51	Shutter pin, M8 Sst.	1	•				3
7	10.3195.01	O-ring, 2,62x20,29 mm Ni 90	1	•				10
8	60.5010.31	Reduction bushing, brass	1					2
9	10.4080.00	Back-up ring, 12x18,2x2 mm	1	•				10
10	10.3234.00	O-ring, 3,53x10,69 mm	1	•				10
11	60.5009.31	Piston holder, brass	1					1

Pos.	P/N	Description	Q.ty	K1	K2	K3	K4	
12	60.5011.61	Valve regulating screw, M10x44 z.pl.	1					3
13	11.4629.00	Hex. nut, M10	1					10
14	60.5008.31	Upper plug, M10 brass	1					1
15	60.5007.31	Spring guide spacer, brass	1					3
16	60.5006.61	Spring, 6x30x62 mm	1					5
17	60.5005.31	Spring guide spacer, brass	1					1
18	14.7461.00	Ball, 13/32" Sst.	1					10
19	10.4081.00	Back-up ring, 15,8x22x2 mm	1	•				10
20	10.3237.00	O-ring, 3,53x15,47 mm	1	•				10
21	60.5004.51	Piston, M8 Sst.	1					2

Kit	P/N	Description	
K1	60.0546.24	Spares kit -Vrp 175, 9x1pcs.	1