



**P.A. – S.p.A. – EQUIPAGGIAMENTI TECNICI DEL LAVAGGIO**

VIA MILANO, 13 – CASELLA POSTALE 115 – 42048 RUBIERA (REGGIO EMILIA) – ITALY  
 Tel. +39 0522 623611 – Fax. +39 0522 629600 – R.E.A. RE 156319 – R.I. RE11535 – Mecc. RE 013446  
 C.F. e P. IVA 01035950359 – Cap. Soc. i.v. € 750.000,00 – Codice Identificativo C.E.E. IT 01035950359  
 ART. 2497 – BIS C.C. DIREZIONE E COORDINAMENTO BENETTI srl R.I. TRIB. DI RE 01480690351  
 Web: <http://www.pa-etf.it> – E-mail: [info@pa-etf.it](mailto:info@pa-etf.it)



## VRPP 450/200 – Pressure regulating valve by pneumatic control

Technical manual: **I 271**

The Valve, fed by compressed air, maintains the pressure steady throughout the circuit discharging in bypass the excess water. If the supply of the compressed air is interrupted, the circuit goes into low pressure.



- **60.5360.00** VRPP 450/200 G 1”1/4 FF

- Pneumatic piston control.
- Pneumatic piston at max pressure => max pressure defined; without air pressure => circuit in low pressure
- Possibility to vary the work pressure by adjusting the air feed pressure
- Possibility to adjust the max pressure mechanically.
- Usable with a multiple number of lances.
- High balancing to guarantee slight variations of the rated pressure when the flow varies in bypass.
- Diameter 8.5 mm Holes for fixing screws

Technical specifications												
Construction material			Brass body and internal parts in Sst Alluminium Pneumatic Jack									
Rated temperature (1)			90°C									
Rated diameter			DN 32									
PART NUMBER	RATED PRESSURE		PERMISSIBLE PRESSURE		MINIMUM ADJUSTABLE PRESSURE		MAXIMUM AIR PRESSURE		MAXIMUM FLOW RATE	WEIGHT	INLET OUTLET BYPASS	
	bar	MPa	bar	MPa	bar	MPa	bar	MPa	l/min	g		
60.5360.00	200	20	220	22	20	2	10	1	450	8500	G 1”1/4 F	

(1) The valve has been designed for a continuous use at a water temperature of 60°C. It can resist for short periods at a maximum temperature of 90°C.

**DIMENSIONAL DRAWING**

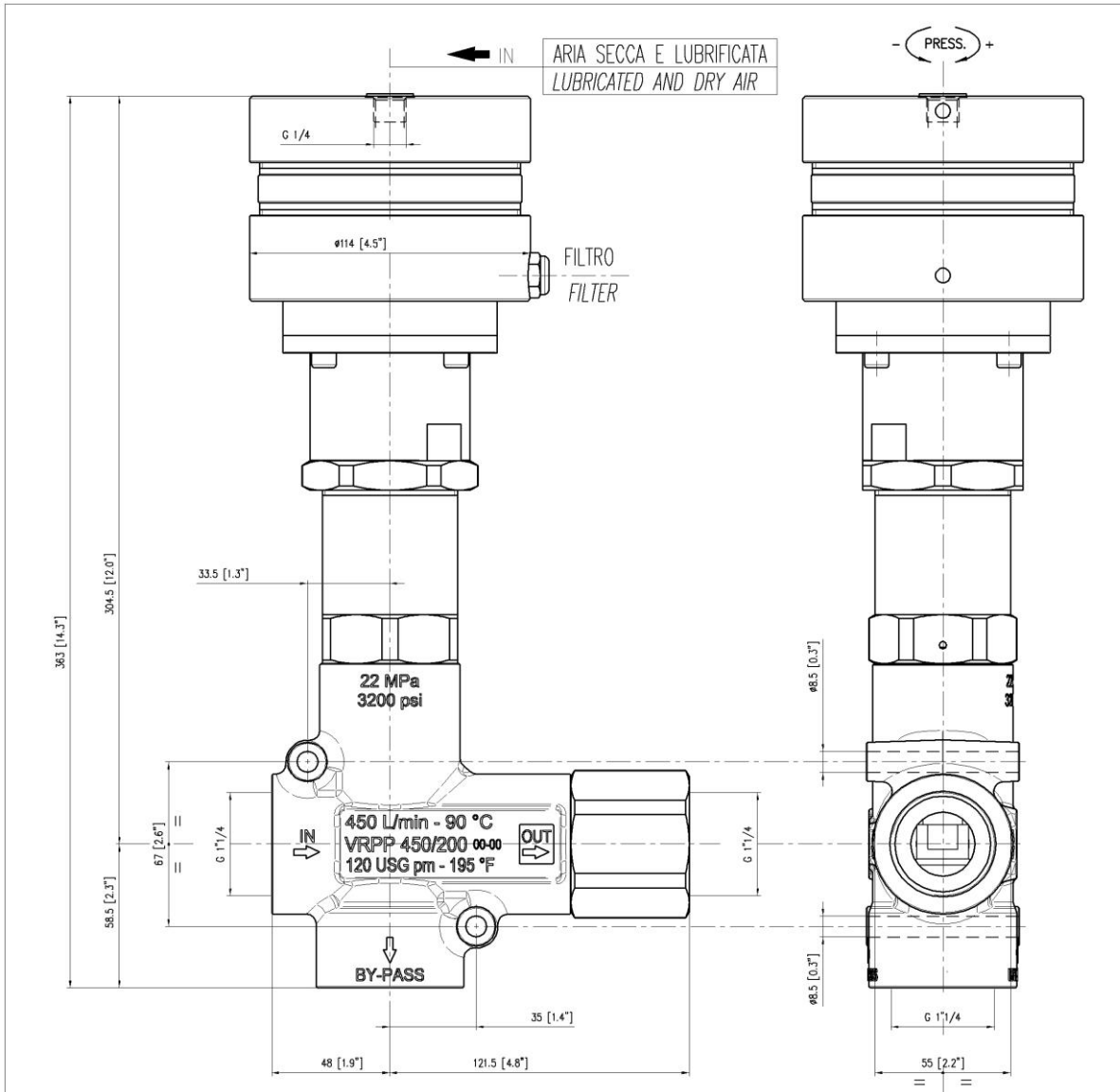

**DESCRIPTION**

The valve has an inlet fitting, an outlet fitting and a bypass fitting with G 1" ¼ F threading. A pneumatic jack is fitted to the valve with a feed fitting G ¼" F thread.

**SELECTION**

This product is to be utilized with clean fresh water, even slightly additivated with normal detergents. For use involving different or corrosive liquids, contact the PA Technical department. Appropriate filtration should be installed when using unclean liquids. Choose the valve in line with the running data of the machine where to be installed (rated pressure, max flow and max temperature of the system). In any case, no machine overpressure has to exceed the permissible pressure imprinted on the valve.

**FUNCTION**

The valve regulates the max pressure of the system altering the flow discharged by the bypass. The adjustment is carried out by changing, through means of a piston, the position of a shutter that partially closes the bypass opening.

**INSTALLATION**

This product is bound to be incorporated on a finished machine. This accessory, on a machine that produces hot water must be fitted upstream to the heat generator. On a system that generates hot water, anticipate the fitting of accessories that limit the accidental increase of fluid temperature.

**ALWAYS INSTALL A SAFETY VALVE IN THE CIRCUIT.**

The pneumatic jack has to be fed with dry air and lubricated to the maximum pressure of 10 bar – 1 Mpa.  
 It is recommended to use a nozzle with a flow rate that at gun opening, permits to discharge regularly from the bypass of the valve at least 5% of the flow supplied by the pump in order to have a constant pressure value, easy adjustment and to avoid troublesome pressure spikes at gun closure.  
 If the nozzle wears out, the working pressure drops. To revive the working pressure, change the worn out nozzle. On installation of a new nozzle, re-adjust the system to the original working pressure.

**DISCHARGE SYSTEM AND WATER ADDUCTION**

We recommend to fit the valve with bypass discharge to a tank. It is advisable that the tank be fitted with deflectors to reduce eventual turbulence and air bubbles generated by the immission of the bypass flow which could be harmful for the pump. With elevated flow or near to the maximum flow of the valve, the installation with a recirculation of bypass direct to the pump could cause potential pressure spikes harmful to the pump.

**PRESSURE ADJUSTMENT/SETTING**

The adjustment has to be made with the system under pressure and the gun open and with the air feed pressure at 4 bar – 0.4 MPa.  
 Vary the pressure by screwing/unscrewing the attachment in which the jack head is fitted (pos 16) by means of an Hex key 62. This operation will result easy if the correct nozzle has been chosen. When the attachment is tightened (pos 16) a consequent increase of pressure has to correspond; if, before reaching the desired value during tightening the pressure increase does not correspond, **do not insist** but verify the correct ratio nozzle/flow pressure. Upon reaching the desired pressure, tighten the nut (pos 17). After setting the maximum pressure, **it is possible anyhow to vary the valve work pressure by adjusting the air feed pressure**. By increasing air feed pressure, valve pressure will increase as well. To decrease valve pressure, it is necessary to reset air pressure and subsequently increase it again up to the desired pressure level. If the air feed is interrupted the complete circuit will go into low pressure.

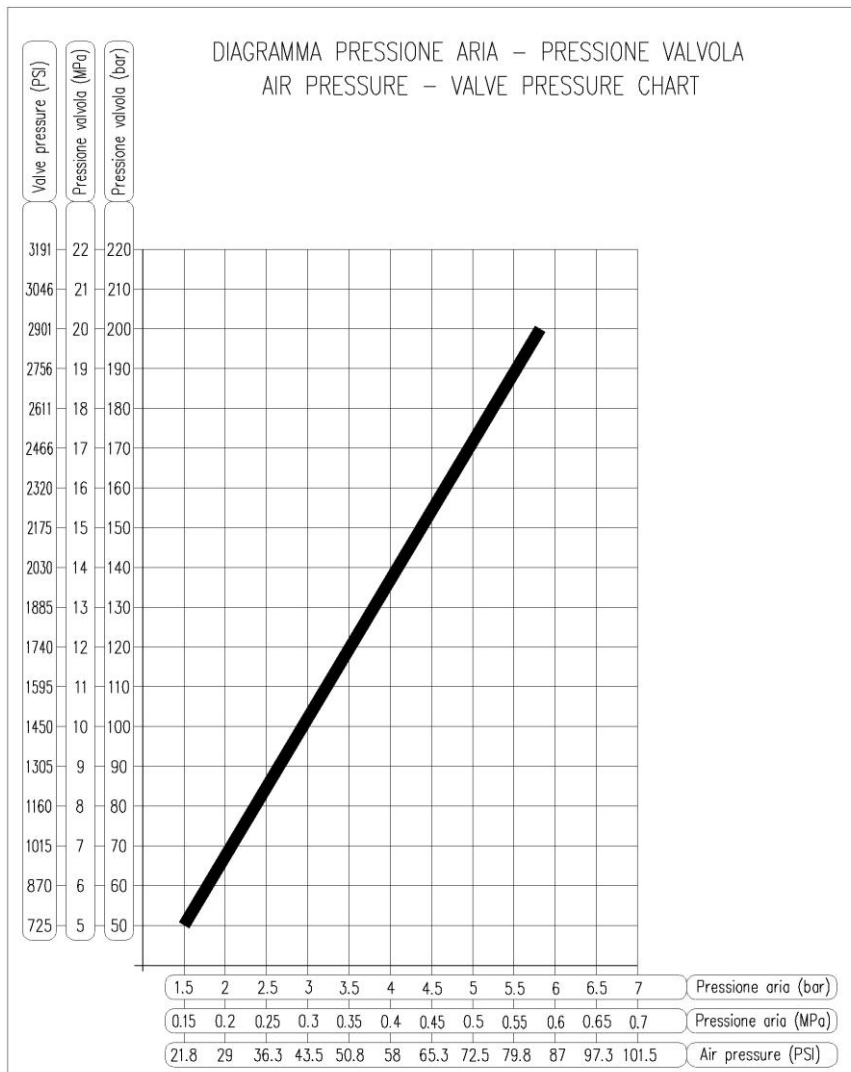

**PROBLEMS AND SOLUTIONS**

PROBLEMS	PROBABLE CAUSES	SOLUTIONS
Valve cycles	<ul style="list-style-type: none"> <li>- Air inside the system</li> <li>- Worn out seals</li> <li>- Clogged bypass or diameter too small</li> </ul>	<ul style="list-style-type: none"> <li>- Flush out</li> <li>- Replace</li> <li>- Clean or widen passages</li> </ul>
The valve does not reach working pressure	<ul style="list-style-type: none"> <li>- Piston seals ruined</li> <li>- Presence of impurities between seat and shutter</li> <li>- Seat &amp; shutter worn out</li> <li>- Nozzle worn out</li> <li>- Incorrect choice of nozzle</li> <li>- Air shortage in pneumatic jack</li> <li>- Air pressure too low</li> <li>- Pneumatic jack seals worn out</li> </ul>	<ul style="list-style-type: none"> <li>- Replace</li> <li>- Clean seat</li> <li>- Replace</li> <li>- Replace</li> <li>- Fit nozzle with inferior flow factor</li> <li>- Open air compressed feed</li> <li>- Reset air pressure to circa 4 bar</li> <li>- Replace</li> </ul>
Pressure spikes	<ul style="list-style-type: none"> <li>- Minus min.5% of total flow in discharge</li> <li>- Clogged nozzle</li> </ul>	<ul style="list-style-type: none"> <li>- Re-adjust correctly</li> <li>- Clean or replace</li> </ul>

**MAINTENANCE**

STANDARD: every 400 working hours (circa 10,000 cycles), check and lubricate the seals with water resistant grease.

SPECIAL: every 800 working hours( circa 20,000 cycles), control the wear of the seals and internal parts and if necessary, replace with original PA parts taking care during installation and to lubricate with water resistant grease.

Maintenance has to be carried out by **Specialized Technicians**.

**The manufacturer is not to be considered responsible for damage as a result from incorrect fitting and maintenance**

**REGULATIONS :** *see norm manual*

For a correct utilization, follow the directions described in this manual and re-print them on the Use and maintenance manual of the machine.

Make sure that you are given **the Original Conformity Declaration** for the accessory chosen. The present manual is valid for all unloader valves named **VRPP 450/200**.

Technical data, descriptions and illustrations are indicative and liable to modification without notice.

<b>Instruction manual, maintenance, installation, spare parts</b> For a correct utilization, follow the directions of this manual <b><u>Re-print them on the Use and Maintenance booklet of the machine.</u></b>	n. 12.9271.00