

Oil burners fuel unit with solenoid valve Type VM

www.deltapumps.com



VM1 - VM4U flanged

Oil burners fuel unit with solenoid valve

Type VM

The DELTA fuel unit is an efficient modern oil burner pump with compact design and since its mounting flange, hub and shaft sizes are manufactured to international standards (EN 225), it can be fitted to every oil burner.

1- Features

- High suction capability.
- Suitable for one or two pipe systems.
- Self priming.
- Reliable pressure and positive cut-off.
- Solenoid valve incorporated.
- Special rotary shaft seal.
- Silent operation.
- Low power absorption.
- Easily installed and adjusted.
- Pressure and vacuum gauge ports.

2- Applications

The DELTA fuel unit type VM is designed for pumping oil in high pressure oil burners and transfer pump applications.

WARNING

It must not be used to pump water or acid.

3- Operation

The VM fuel unit consists of a pump, solenoid valve, filter and pressure regulator valve housed within one casting. The pumping action is obtained from two spur gears (2), one of which is connected to the drive shaft (3). The pump casting provides the various oil ways, for the suction (6), return (5) and nozzle (9) ports. Pressure (8) and vacuum (7) gauge ports are also provided.

The VM unit is available in two pipe and one pipe version. Both versions are self priming.

On start up, the rotating gears purge the air from the suction chamber, through a vent groove in the piston to the return line in two pipe version, and through the nozzle line (after the solenoid valve opening) in one pipe version.

On initial commissioning, it is possible to bleed the air more quickly, through the pressure gauge.

Because a vacuum now exists oil, due to atmospheric pressure, enters the suction chamber through the filter.

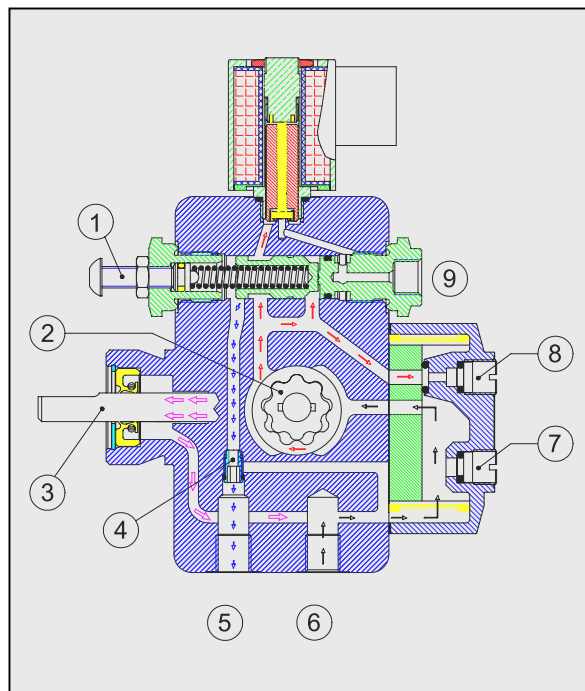

From the suction side, the gears pass the oil to the pressure chamber, where it comes up against the head of the piston. Due to the build up of pressure, the piston is forced back against the pressure regulating spring. The flow of pressurized oil is interrupted by an incorporated solenoid valve (10), and can, therefore, be opened following the start of the motor (pre-purge), or interrupted before stopping the motor itself (instant shut-off of the flame preventing the nozzle dripping). The excessive oil discharges to the return side (or by-passes in the one pipe version). It will be realized of course that the spring tension, which is varied by the regulator screw (1), regulates the pressure of oil required.

The pump can be converted from the single pipe version to the two pipe version, fitting the by-pass plug (4) in the return port.

4- Pump identification

VM 1 R L 2 4 P F

Pump type

Nozzle capacity

(see graphs)

Rotation (seen from shaft end)

R = clockwise

L = counter clockwise

Nozzle line (seen from cover)

R = right

L = left

Pipes system

1 = one pipe

2 = two pipes

Pressure ranges

3 = 2 ÷ 10 bar

4 = 4 ÷ 15 bar (Standard)

5 = 8 ÷ 20 bar

6 = 10 ÷ 25 bar

Factory setting

4 ±0,3 bar

10 ±0,3 bar

15 ±0,3 bar

20 ±0,3 bar

Special versions

U = cover type U with 65 cm² stainless steel filter, mesh 110μ (without pressure and vacuum gauge)

P = auxiliary pressure port

Coil type

F = F84 coil with connector plug

M = M8 coil with flexible metal conduit

5- Technical specifications

Oil viscosity	1,2 ÷ 50 cSt
Oil temperature	60°C max.
Power consumption	See graphs
Nozzle capacity	See graphs
Suction line vacuum	0,5 bar max.
Suction line pressure	2 bar max.
Return line pressure	2 bar max.
Rotation speed	3500 rpm max.
Standard strainer.....	Nylon mesh 150μ, 20cm ² (VM1 9cm ²)
Dimensions (EN 225)	Hub Ø32, shaft Ø8 (optionals : flanged hub Ø54, shaft 7/16")
Connections (ISO 228/1)	Inlet – Return: G1/4"
	Nozzle port, Pressure / vacuum gauges: G1/8"
Weight	gr. 1100

6- Solenoid valve specifications

Power absorbed	9 W																																			
Voltage tolerance	-15% / +10%																																			
Environment temperature	0°C / 60°C																																			
Working pressure	25 bar max.																																			
Flow factor (VDI/VDE 2173)	0,08 m ³ /h																																			
Cut-off pressure	4 bar																																			
Approval (EN 264)	TÜV No. 5S102/04																																			
Coil specifications	<table> <tr> <td>F84</td> <td>380V 50-60Hz</td> <td>230V 50-60Hz</td> <td>M8</td> <td>230V 50-60Hz L=700mm</td> </tr> <tr> <td></td> <td>110V 50-60Hz</td> <td>24V 50-60Hz</td> <td></td> <td>230V 50-60Hz L=260mm</td> </tr> <tr> <td></td> <td>24V 95Hz</td> <td>24V DC</td> <td></td> <td>110V 60Hz L=700mm</td> </tr> <tr> <td></td> <td>12V DC</td> <td></td> <td></td> <td>24V 50Hz L=300mm</td> </tr> <tr> <td></td> <td>L=300mm</td> <td>L=400mm</td> <td></td> <td>24V 50Hz L=700mm</td> </tr> <tr> <td></td> <td>L=500mm</td> <td>L=700mm</td> <td></td> <td>24V 50Hz L=700mm</td> </tr> <tr> <td></td> <td>L=1000mm</td> <td>L=1600mm</td> <td></td> <td>24V DC L=700mm</td> </tr> </table>	F84	380V 50-60Hz	230V 50-60Hz	M8	230V 50-60Hz L=700mm		110V 50-60Hz	24V 50-60Hz		230V 50-60Hz L=260mm		24V 95Hz	24V DC		110V 60Hz L=700mm		12V DC			24V 50Hz L=300mm		L=300mm	L=400mm		24V 50Hz L=700mm		L=500mm	L=700mm		24V 50Hz L=700mm		L=1000mm	L=1600mm		24V DC L=700mm
F84	380V 50-60Hz	230V 50-60Hz	M8	230V 50-60Hz L=700mm																																
	110V 50-60Hz	24V 50-60Hz		230V 50-60Hz L=260mm																																
	24V 95Hz	24V DC		110V 60Hz L=700mm																																
	12V DC			24V 50Hz L=300mm																																
	L=300mm	L=400mm		24V 50Hz L=700mm																																
	L=500mm	L=700mm		24V 50Hz L=700mm																																
	L=1000mm	L=1600mm		24V DC L=700mm																																



7- Diagrams

Nozzle capacity

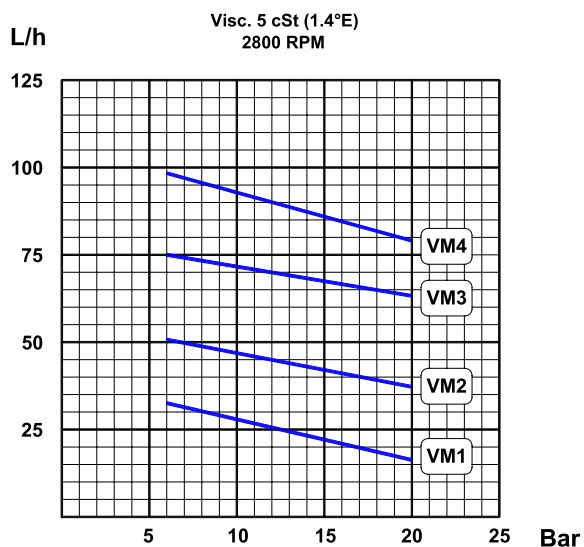

Power consumption

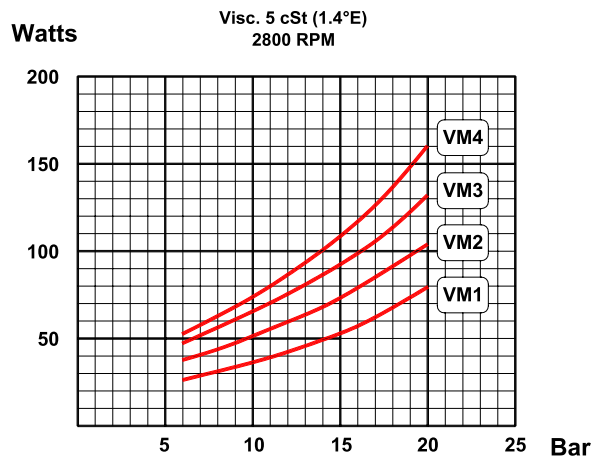

8- Overall dimensions

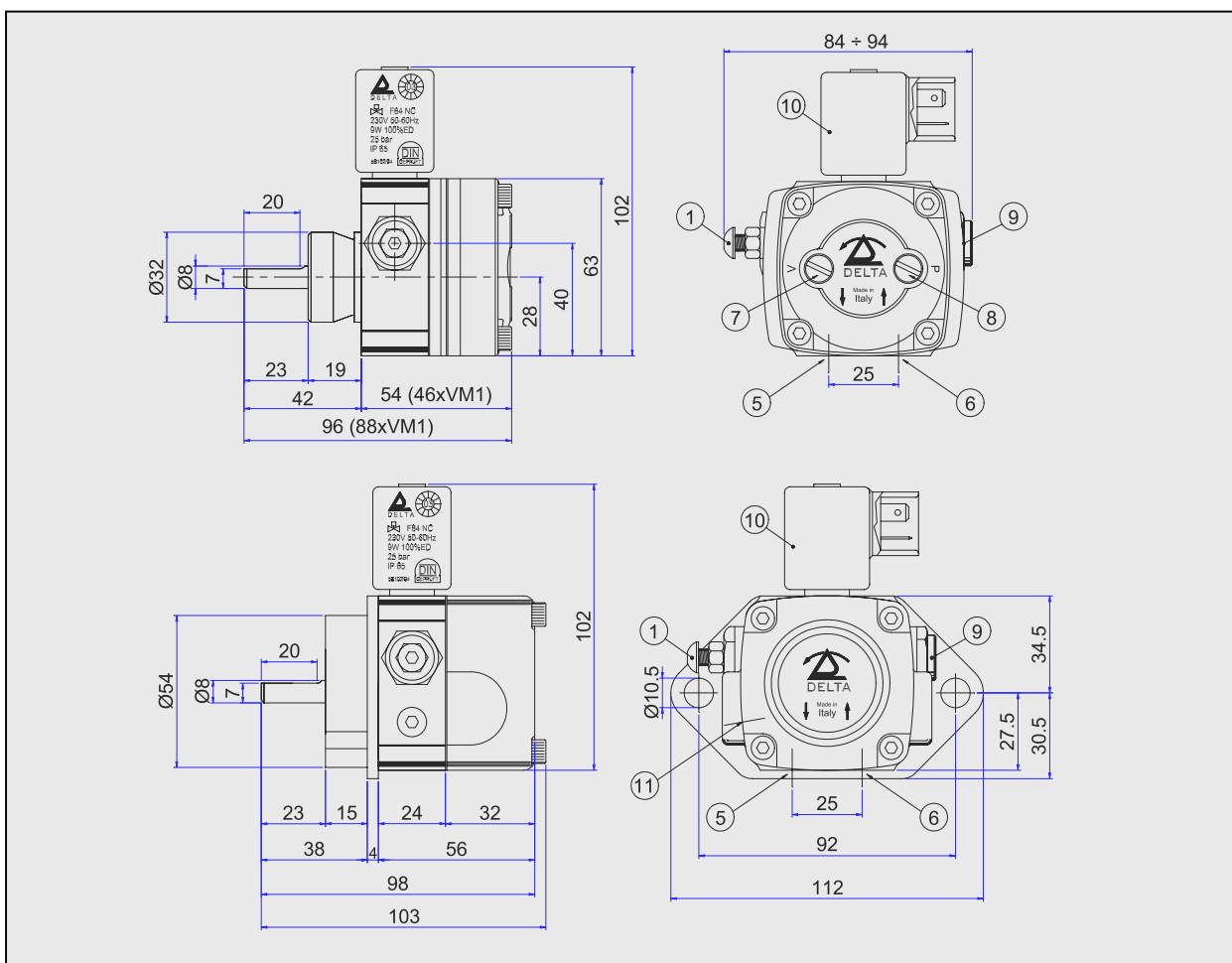

- | | |
|-----------------------|----------------------------|
| 1 Pressure regulation | 8 Pressure gauge |
| 5 Return | 9 Nozzle port |
| 6 Suction | 10 Solenoid valve |
| 7 Vacuum gauge | 11 Auxiliary pressure port |

9- By-pass installation

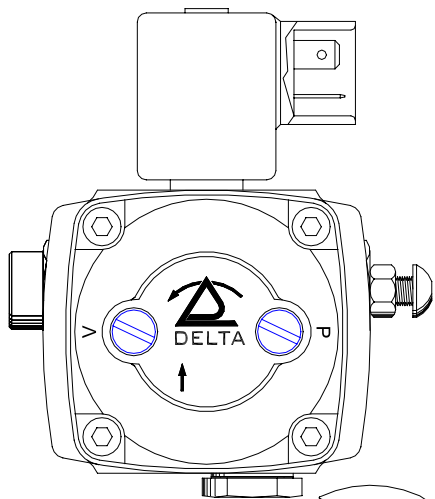

Fig. 1

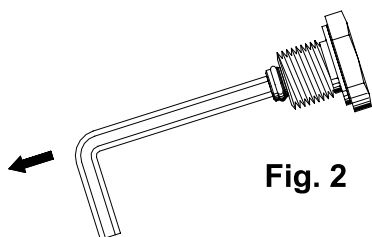
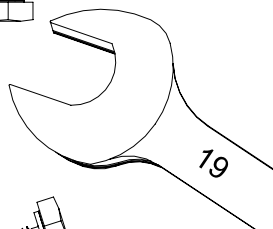

Fig. 2

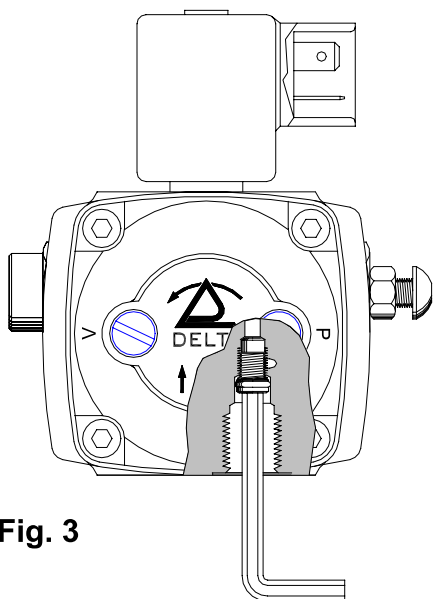

Fig. 3

To convert the DELTA fuel unit from the single pipe version to the two pipe version, do the following:

- a) Using a 19 mm wrench, remove the 1/4" plug from return port (Fig. 1).
- b) Located inside the return plug is the by-pass plug. Remove it with a 4 mm Allen wrench (Fig.2).
- c) Insert and screw the by-pass plug in the return port (Fig. 3).

To convert the DELTA fuel unit from the two pipe version to the single pipe version, do the following:

- d) Using a 4 mm Allen wrench, unscrew the by-pass plug from the return port (Fig. 3).
- e) Insert and screw a 1/4" plug into the return port (Fig. 1).

WARNING

- In the single pipe version, the air is bled through the nozzle line, after the solenoid valve opening.
- In the two pipe version the air is bled through the return port. After conversion, the air must be bled manually, through the pressure gauge.
- Make sure that the by-pass plug is not used in a single pipe installation, because the fuel unit will not function properly and damage to the pump and burner motor could result.

Installation and Service Instructions

10- Installation and Maintenance

1. Make sure that the by-pass plug is not used in a single pipe installation, because the fuel unit will not function properly and damage to the pump and burner motor could result.
2. Do not use fuel with additives to avoid the possible formation over time of compounds which may deposit between the gear teeth, thus obstructing them.
3. After filling the tank, wait before starting the burner. This will give any suspended impurities time to deposit on the bottom of the tank, thus avoiding the possibility that they might be sucked into the pump.
4. On initial commissioning a dry operation is foreseen for a considerable length of time (for example, when there is a long suction line to bleed). To avoid damages inject some lubrication oil into the vacuum inlet.
5. Care must be taken when installing the pump not to force the pump shaft along its axis or laterally to avoid excessive wear on the joint, noise and overloading the gears.
6. Do not force the valve stem and do not use it as lever.
7. Pipes should not contain air pockets. The number of junctions should be kept to a minimum as they are a possible source of leakage.
8. Rapid attachment joint should therefore be avoided. Always use O-Rings or mechanical seal (copper or aluminium gaskets) junctions if possible.
9. Avoid overtightening:
G1/8" → 15 Nm max.
G1/4" → 20 Nm max.
10. Do not use PTFE tape on the suction and return line pipes to avoid the possibility that particles enter circulation. These could deposit on the pump filter or the nozzle, reducing efficiency.
11. When junction threads, elbow joints and couplings are sealed with removable glue, avoid excessive quantities, which could enter in the oil ways and damage to the pump could result.
12. To clean the filter remove the cover. It must be thoroughly cleaned at least once in a season to ensure correct working of the fuel unit. The filter must be mounted with the supporting legs leaned against the pump body. If the joint plate between cover and pump housing should be damaged, it must be replaced. An external filter should always be installed in the suction line upstream of the fuel unit.
13. Make sure the combustion chamber is free of oil or oil vapor before operating the system.

CAUTION: Turn off all power before servicing any part of the system.

11- Nozzle Pressure Test

Most nozzles ratings are based upon 100 PSIG delivered oil pressure. The flow rate at the desired pressure must be estimated using the nozzle manufacturers data sheets.

To insure that oil is delivered to the burner nozzle at the desired pressure, do the following:

1. Remove the 1/8" plug from the port marked "P" and connect a pressure gauge to this port (use a gauge of 0 to 300 PSIG or greater). The "P" port (Pressure Gauge Test Port) has been provided specifically for the connection of the pressure gauge for measuring the nozzle pressure; however, when available, it is also permissible to use the vent port for measuring nozzle pressure.
2. Start the burner motor, energize the solenoid valve and vent all air from the fuel unit and connected suction line system.
3. Check the adjustable nozzle pressure range of the fuel unit, using a 4 mm Allen wrench, turning the adjusting screw counter clockwise to lower the nozzle pressure and clockwise to increase the nozzle pressure.

CAUTION: Adjust the nozzle pressure in accordance with the burner manufacturers specifications.

12- Nozzle Cut-Off Test

Fuel oil is not compressible but air is. Air trapped in the nozzle line, anywhere between the fuel units nozzle port and the nozzle itself, will compress during burner operation. Following burner shutdown, any trapped compressed air will expand displacing the oil in the nozzle line, forcing continued oil flow through the nozzle that will, in effect, falsely appear to be poor fuel unit Cut-Off. This occurrence is particularly common with low flow rate nozzles used in conjunction with long air tubes.

To verify positive nozzle Cut-Off after burner shutdown, do the following:

1. Remove the nozzle line and fitting from the nozzle port of the fuel unit and connect a 1/8" pressure gauge to the nozzle port (a gauge of 300 PSIG or greater be used). It may be more convenient to use a gauge fitted out with an extension nipple or with a line and flare nut to connect directly to the fitting installed into the nozzle port. If any type of extension is used between the nozzle port and the gauge, it should be kept as short as possible to minimize the amount of trapped air.
2. Start the burner motor, energize the solenoid valve and vent all air from the fuel unit and connected suction line system.
3. Shut off the burner motor. Initially the pressure will drop and then stabilize within a second or two. The pressure reading on the gauge should stabilize at 4 bar or greater and hold for at least two minutes.

13- Vacuum Test

The vacuum test is necessary to verify the fuel unit's suction ability, to evaluate the leak tight integrity of the entire fuel unit and connected oil suction line piping system, to confirm that there are no abnormal restrictions in the oil suction line system, and, to confirm that the system vacuum is within the allowable specification limits of the unit. Please watch in any case the graphs for maximum suction line length depending on line diameter, viscosity, difference in height of suction line and pump or nozzle capacity. To perform the test, do the following:

1. Remove the 1/8" plug from the port marked "V" and connect a vacuum gauge to this port.
2. Start the burner motor, energize the solenoid valve and vent all air from the fuel unit and connected suction line system.
3. With the burner motor running, close the valve connected to the inlet port. You will note that the vacuum as measured by the vacuum gauge will increase. Allow the burner motor to continue to run until the highest vacuum reading is achieved. A fully primed fuel unit in good condition should be capable of pulling at least 20 InHg. If not, before condemning the fuel unit, be sure that all connections and plugs are tight, the cover gasket is in good condition and the valve is in good working order.
4. De-energize the solenoid valve and shut off the burner motor. Initially, the vacuum reading will drop and then stabilize within a second or two. Once the vacuum reading stabilizes, record the reading. If the fuel unit is free of leaks, this reading should hold constant for at least 2 minutes. If the vacuum reading drops, there is a leak that must be located and corrected.
5. When each leakage is removed and the valve onto suction line is open, check to be sure that the actual operating vacuum does not exceed 15 InHg.

Elettromeccanica Delta S.p.a. reserves the right to update or make technical changes without prior notice.