



RIDUTTORI PER MOTORI A SCOPPIO
GEARBOX FOR PETROL ENGINES

B10-B18
B18-D25



8 09

12.9809.00

13/02/07

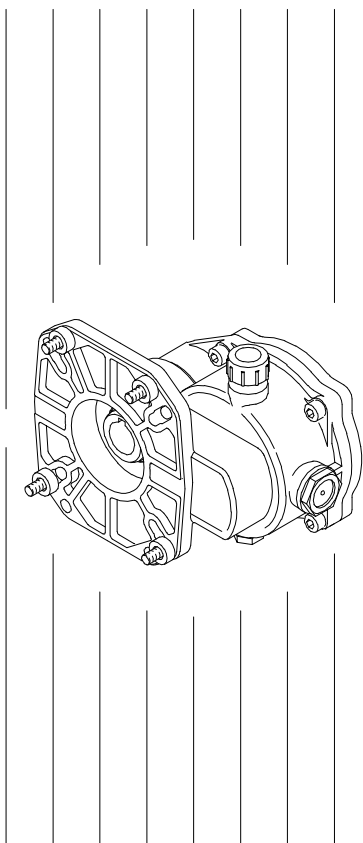

- Di facile montaggio e di buona estetica, questo riduttore permette, in maniera rapida, l'accoppiamento diretto Pompa-Motore a scoppio, dando origine ad un gruppo compatto interamente supportato dal motore.
 - Gli ingranaggi a dentatura elicoidale, con lubrificazione indipendente a bagno d'olio, sono costruiti in acciaio di alta qualità induriti con trattamento di cementazione, per un funzionamento silenzioso e di lunga durata.
 - Flangia attacco motore universale, che permette l'applicazione delle varie marche e modelli di motori a scoppio in commercio.
-
- Easy to mount and of good design this gearbox allows a quick direct coupling Pump-Engine, making a compact unit fully supported by the engine.
 - The gears at helical toothing, with independent lubrication in oil bath, are made in premium quality steel hardened with cementation treatment for a noiseless running and extended life.
 - Universal flange for engine coupling to different makes and models of engines on the market.

CARATTERISTICHE TECNICHE
SPECIFICATIONS

	B10	B18		B18-D25
	50.0100.00	50.0000.00	50.0040.00	50.0000.25
- DIAMETRO ALBERO MOTORE ENGINE SHAFT DIAMETER	25.4 (1")	25.4 (1")	28.6 (1"1/8)	25
- POTENZA MOTORE ENGINE HORSEPOWER	7÷10HP (5÷7Kw)	11÷18HP (8÷13Kw)	11÷18HP (8÷13Kw)	MAX.18HP (13Kw)
- MOTORI ENGINES	FLANGIA FLANGE SAE J609b			
- RAPPORTO DI RIDUZIONE GEAR RATIO	2.176 : 1 (3100/1425 RPM)			
- CAPACITA' OLIO GEARBOX OIL CAPACITY	0.35 l (10 oz.)			
- OLIO LUBRIFICAZIONE LUBRICATION OIL	SAE 90			
- PESO WEIGHT	3950 g (139.3 oz.)			
- POMPE PUMPS	ANNOVI & REVERBERI - BERTOLINI - COMET - INTERPUMP - LEUCO (HAWK) - UDOR			

RIDUTTORI
GEARBOX

B10-B18

DIMENSIONI
d'ingombro
Overall
DIMENSIONS

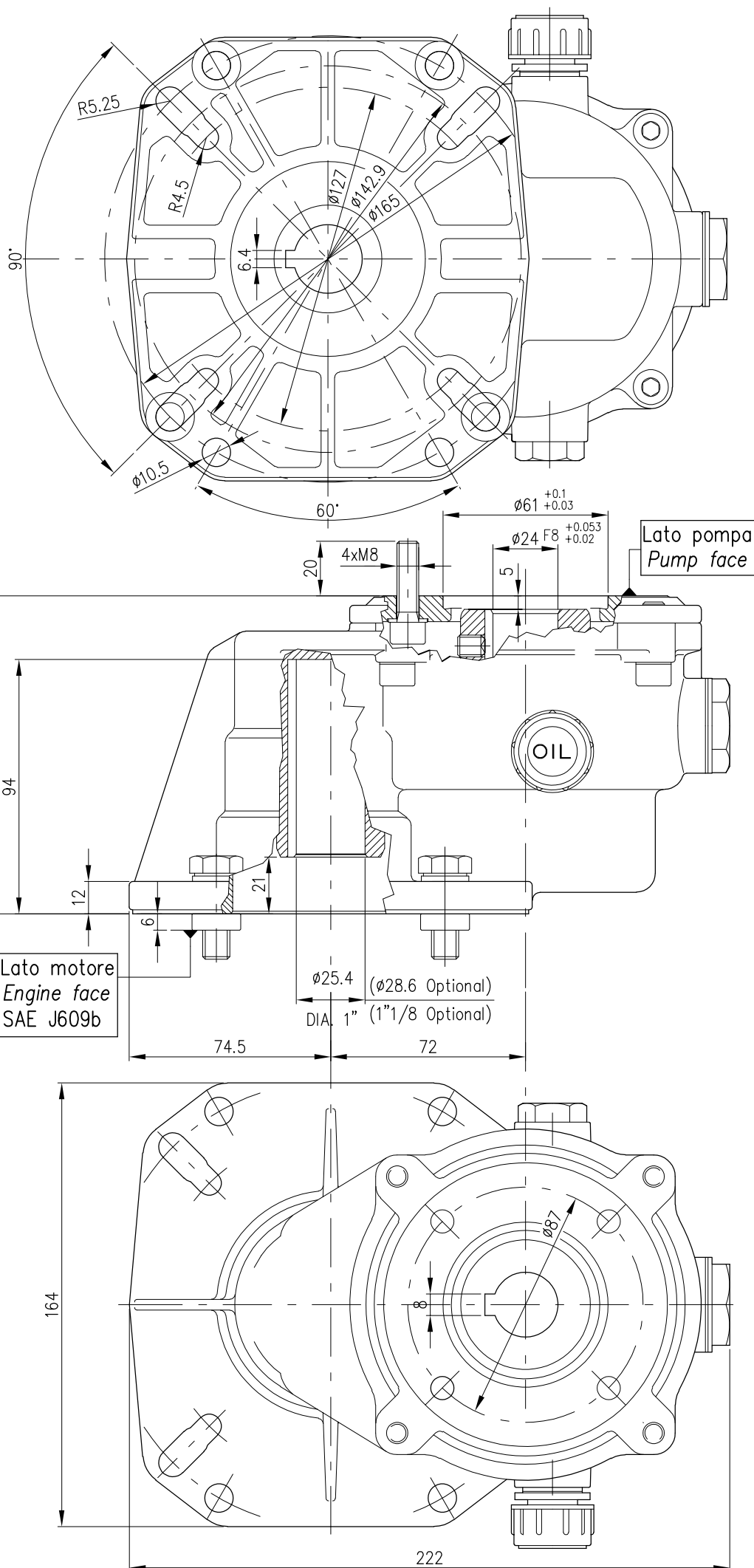

RIDUTTORE
GEARBOX
B18-D25

DIMENSIONI
d'ingombro
Overall
DIMENSIONS

