



RIDUTTORI PER MOTORI A SCOPPIO
GEARBOX FOR PETROL ENGINES

B24
B31



8 24

12.9824.00

23/11/11

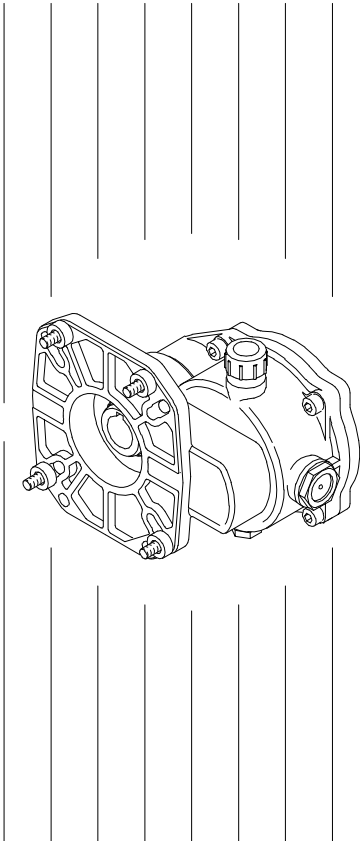

- Di facile montaggio e di buona estetica, questo riduttore permette, in maniera rapida, l'accoppiamento diretto Pompa-Motore a scoppio, dando origine ad un gruppo compatto interamente supportato dal motore.
 - Gli ingranaggi a dentatura elicoidale, con lubrificazione indipendente a bagno d'olio, sono costruiti in acciaio di alta qualità induriti con trattamento di cementazione, per un funzionamento silenzioso e di lunga durata.
 - Flangia attacco motore universale, che permette l'applicazione delle varie marche e modelli di motori a scoppio in commercio.
-
- Easy to mount and of good design this gearbox allows a quick direct coupling Pump-Engine, making a compact unit fully supported by the engine.
 - The gears at helical toothing, with independent lubrication in oil bath, are made in premium quality steel hardened with cementation treatment for a noiseless running and extended life.
 - Universal flange for engine coupling to different makes and models of engines on the market.

CARATTERISTICHE TECNICHE
SPECIFICATIONS

| | B24 | | B31 | B31 ▲ |
|---|--|-------------|--------------------|------------|
| | 50.0060.00 | 50.0062.00 | 50.0071.00 | 50.0071.30 |
| - DIAMETRO ALBERO MOTORE ENGINE SHAFT DIAMETER | 28.6 (1" 1/8) | 25.4 (1") | 28.6 (1" 1/8) | |
| - POTENZA MOTORE ENGINE HORSEPOWER | MAX. 24HP (17.7Kw) | | MAX. 31HP (23.0Kw) | |
| - MOTORI ENGINES | FLANGIA FLANGE SAE J609b | | | |
| - RAPPORTO DI RIDUZIONE GEAR RATIO | 2.176 : 1 (3100/1425 RPM) | | | |
| - CAPACITA' OLIO GEARBOX OIL CAPACITY | 0.35 l (10 oz.) | | | |
| - OLIO LUBRIFICAZIONE LUBRICATION OIL | SAE 90 | | | |
| - PESO WEIGHT | 3950 g (139.3 oz.) | | | |
| - POMPE PUMPS | ANNOVI & REVERBERI - BERTOLINI - COMET - INTERPUMP - LEUCO (HAWK) - UDOR | | | |

RIDUTTORI
GEARBOX
B24
B31

DIMENSIONI
d'ingombro
Overall
DIMENSIONS

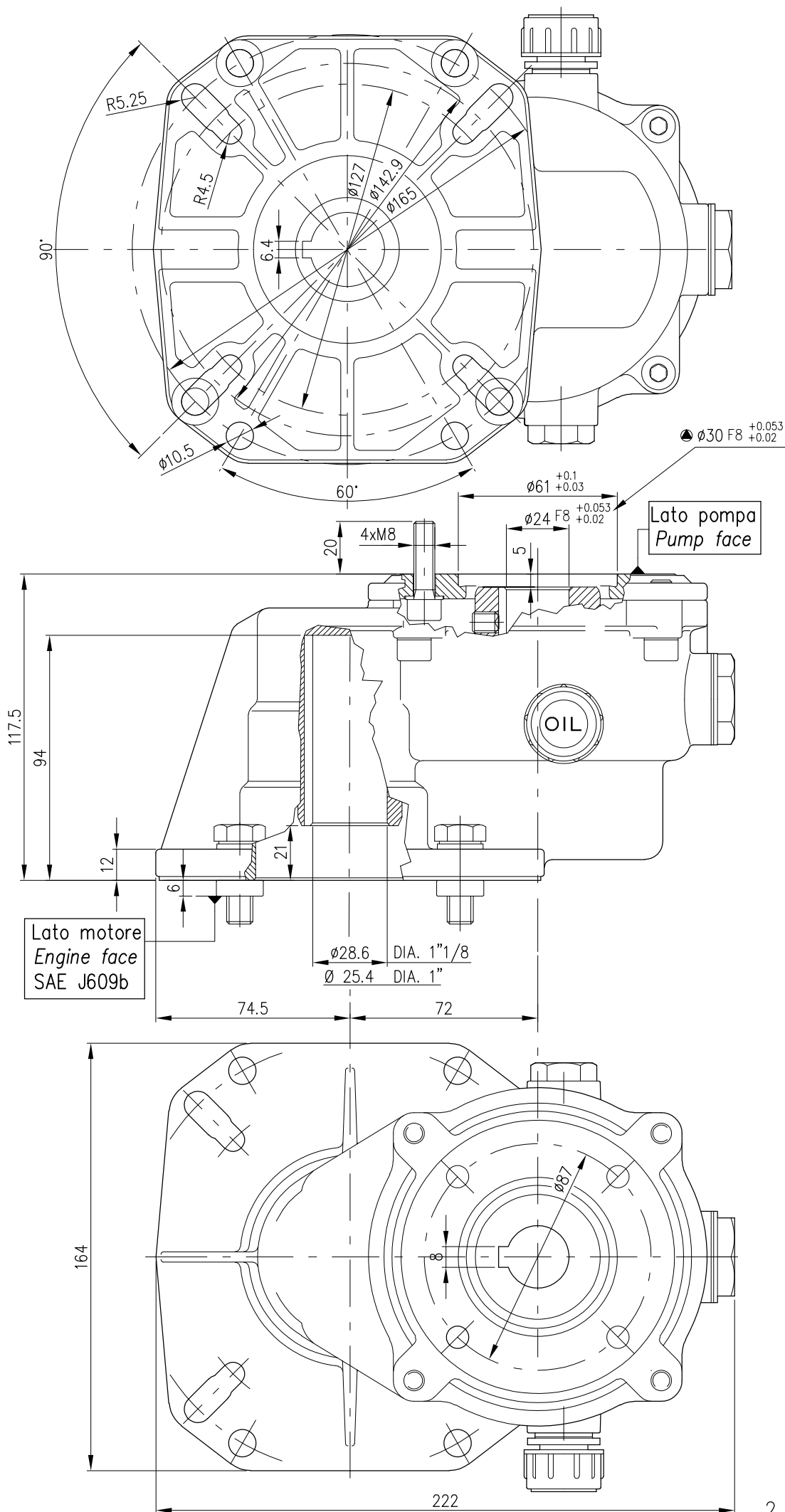

ASSEMBLY INSTRUCTIONS

ASSEMBLY OF THE GEARBOX ON PUMPS:

- Having the pump shaft on vertical position loosen the four bolts which keep the bearing cover to the pump housing leaving it in its position.
- After having set the O Ring 10.3210.56 in its seating, fix the flange 50.0002.44 with the bolts 16.1958.31 with the pertinent seal washers, setting on the threaded part LOCTITE 242 and fix it with 25 Nm (221 in.lbs.) MAX.
- Make sure that the key is correctly set on the keyway, assemble the toothed crown 50.0003.65 on the pump shaft pushing it on the suitable shoulder and clamp it with the screw 16.2223.00 with a torque of 20 Nm (177 in.lbs.) MAX (**use LOCTITE 242**).
- Complete the assembly of the body (preassembled gear box with pinion, bearings and oil seal) with the oil level pilot light 15.3734.00 and the discharge plug 60.0028.31 with pertinent gasket.
- Insert the O Ring 10.3211.11 on the flange already fixed to the pump, and proceed to the assembly of the body on that same flange using the bolts 16.1958.26 and pertinent elastic washers with a torque of 25 Nm (221 in.lbs) MAX. To use a torque wrench with a hex key insert with a ball head as shown in the picture attached.
- At this stage it is possible to proceed to the filling of the housing with oil (type gear-differential SAE 90) up to the level shown at the center of the pilot light, locking it with the vented plug 15.3726.00. In case the unit gearbox-pump is not immediately coupled to the engine, and should it be transported, it is advised to use temporarily the plug 15.3725.00 and gasket, which are supplied for this utilization.



ASSEMBLY THE UNIT GEARBOX-PUMP ON ENGINE:

- Check that the key of the Engine shaft is correctly set on the keyway **then apply on the same shaft a good lubricating antiscruff (type LOCTITE 8150) to facilitate the possible disassembly.**
- Proceed to the coupling of the gearbox to the engine utilizing for the fixing the bolts and the washers supplied.
- Torque to apply on screws for assembly MAX.
 - Screw 16.2010.00 3/8" torque 40Nm (354in.lbs.);
 - Screw 16.2009.00 5/16" torque 25Nm (221in.lbs.);
 - Screw 16.2035.00 M10 torque 40Nm (354in.lbs.);
 - Screw 16.1957.30 M8 torque 25Nm (221in.lbs.).**If the engine has a short shaft, lock the feather key axially. For instance: screw washer or set screw, etc...**

50.0060.00 B24 Gear box 18-24 HP r.2,176:1
 50.0062.00 B24 Gear box 18-24 HP r.2,176:1

50.0071.00 B31 Gear box 24-31 Hp-r.2,176:1
 50.0071.30 B31 Gear box 24-31 Hp-r.2,176:1-30mm

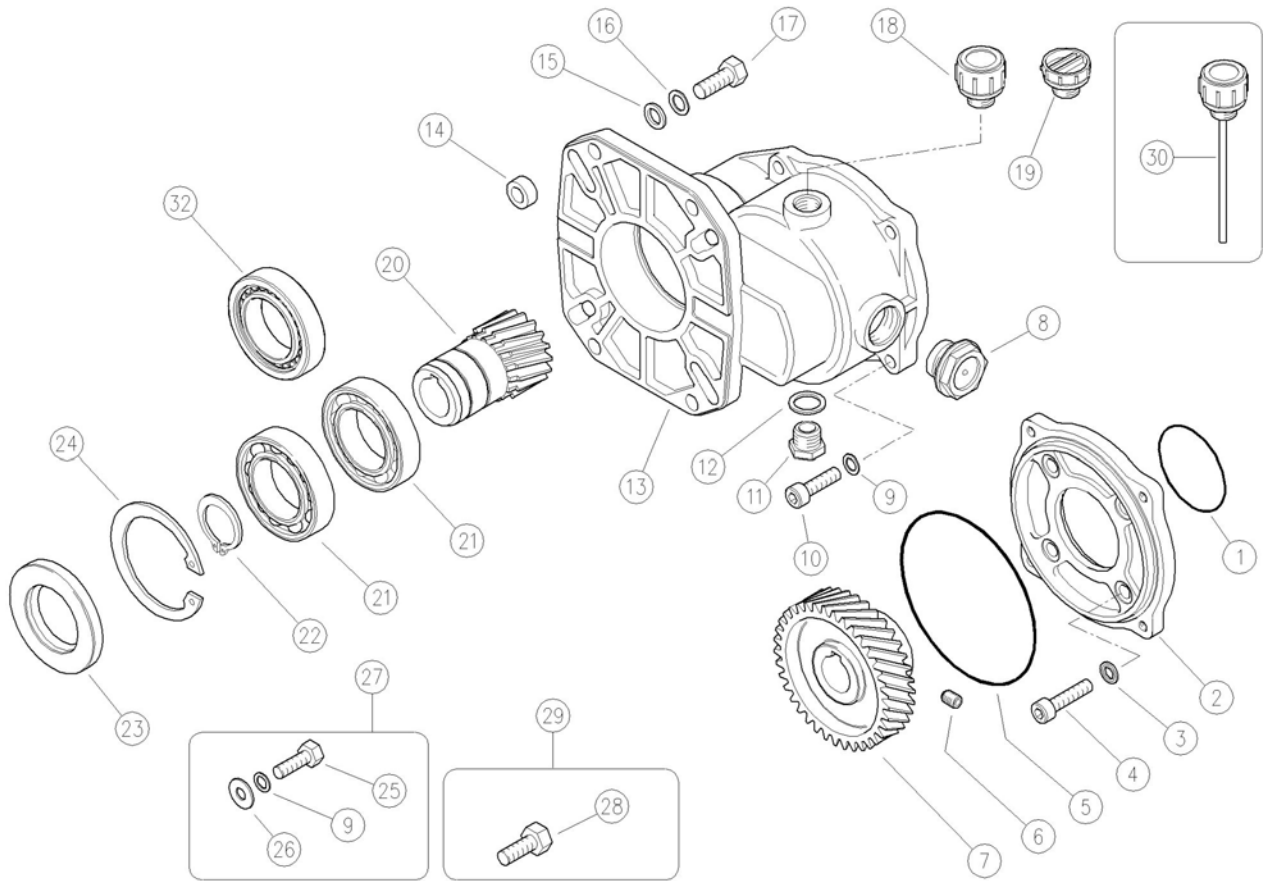

| Pos. | P/N | Description | Q.ty | K1 | K2 | K3 | K4 | | Pos. | P/N | Description | Q.ty | K1 | K2 | K3 | K4 | |
|------|------------|------------------------------------|------|----|----|----|----|----|------|------------|---|------|----|----|----|----|----|
| 1 | 10.3210.56 | O-ring, 2,62x56,82 mm | 1 | | | | | 10 | 17 | 16.2010.00 | Screw, DIN933 3/8"UNCx1"1/4 z.pl. | 4 | | | | | 4 |
| 2 | 50.0002.44 | Gearbox flange, alum. | 1 | | | | | 1 | 18 | 15.3726.00 | Oil plug 3/8" Bsp+seal | 1 | | | | | 5 |
| 3 | 14.4098.00 | Sealing washer, d.8 mm | 4 | | | | | 5 | 19 | 15.3725.00 | Plug, 3/8" Bsp plast. | 1 | | | | | 5 |
| 4 | 16.1958.31 | Screw, DIN912 M8x30 mm z.pl. | 4 | | | | | 4 | 20 | 50.0006.21 | Pinion, Z.17 d.1" (25,4mm) complete (2) | 1 | | | | | 1 |
| 5 | 10.3211.11 | O-ring, 2,62x113,92 mm | 1 | | | | | 10 | 20 | 50.0007.21 | Pinion, Z.17 d.1"1/8 (28,6mm) complete | 1 | | | | | 1 |
| 6 | 16.2223.00 | Set screw, DIN916 M8x10 mm | 1 | | | | | 10 | 21 | 11.4441.68 | Ball-bearing, 40x68x15 mm (1,2) | 2 | | | | | 2 |
| 7 | 50.0003.65 | Ring gear, Z.37 d.24mm (1,2,3) | 1 | | | | | 1 | 21 | 11.4441.68 | Ball-bearing, 40x68x15 mm (3,4) | 1 | | | | | 2 |
| 7 | 50.0072.65 | Ring gear, Z.37 d.30mm (4) | 1 | | | | | 1 | 22 | 10.1040.00 | Snap ring, E 40 | 1 | | | | | 5 |
| 8 | 15.3734.00 | See-through oil plug 3/4" Bsp+seal | 1 | | | | | 5 | 23 | 10.2040.72 | Seal ring, 40x72x7 mm | 1 | | | | | 3 |
| 9 | 14.3652.00 | Safet. washer, 8,4x13x0,8 mm | 8 | | | | | 10 | 24 | 10.1072.00 | Snap ring, I 72 | 1 | | | | | 5 |
| 10 | 16.1958.26 | Screw, DIN912 M8x25 mm z.pl. | 4 | | | | | 4 | 25 | 16.2009.00 | Screw, DIN933 5/16"UNF1" z.pl. | 4 | | | | | 4 |
| 11 | 60.0028.31 | Plug,brass 3/8 Bsp,hex.19 | 1 | | | | | 25 | 26 | 14.3572.00 | Washer, 8,4x21x1,5 mm | 4 | | | | | 10 |
| 12 | 14.4042.00 | Washer, 16,7x22x1,5 mm alu. | 1 | | | | | 25 | 27 | 50.0010.24 | Lock-Kit, 127mm,5/16"screws+washers | 1 | | | | | 1 |
| 13 | 50.0001.44 | Gearbox case, alum. | 1 | | | | | 1 | 28 | 16.2035.00 | Screw, DIN933 M10x35 mm z.pl. ** | 4 | | | | | 10 |
| 14 | 50.0008.31 | Spacer ring, 10,3x18x6 mm brass | 4 | | | | | 4 | 29 | 50.0011.24 | Lock-Kit, 165mm, M10 screws ** | 1 | | | | | 1 |
| 15 | 14.3798.00 | Washer, 10,5x17x2 mm | 4 | | | | | 10 | 30 | 15.3728.00 | Oil plug +dipstick ** | 1 | | | | | 3 |
| 16 | 14.3653.00 | Safet. washer, 10,5x16x1 mm | 4 | | | | | 10 | 32 | 11.4445.68 | Bearing, 40x68x15 mm (3,4) | 1 | | | | | 2 |

** On request

(1) 50.0060.00 (2) 50.0062.00 (3) 50.0071.00 (4) 50.0071.30