

Serie KT-KTB-WK-W



**INTERPUMP
GROUP**



Pratissoli

**KT24 - KT26 - KT28 -KT30 - KT32 - KT34 - KT36- KT40 -
KT36B - KT40B - WK155 - WK6 - WK8 - W120120 - W100140**



Use and Maintenance Manual

Contents

1	INTRODUCTION	22
2	DESCRIPTION OF SYMBOLS	22
3	SAFETY	22
3.1	General safety warnings	22
3.2	Essential safety in the high pressure system.....	22
3.3	Safety during work	22
3.4	Rules of conduct for the use of lances.....	22
3.5	Safety during system maintenance.....	23
4	PUMP IDENTIFICATION	23
5	TECHNICAL CHARACTERISTICS	24
6	DIMENSIONS AND WEIGHT	24
7	OPERATING INSTRUCTIONS.....	25
7.1	Water temperature	25
7.2	Maximum pressure and flow rate	25
7.3	Minimum operating speed	25
7.4	Sound emission	25
7.5	Vibration.....	25
7.6	Brands and types of oils recommended.....	25
8	PORTS AND CONNECTIONS	26
9	PUMP INSTALLATION	27
9.1	Installation.....	27
9.2	Rotation direction.....	27
9.3	Version change	27
9.4	Hydraulic connections	28
9.5	Pump supply.....	28
9.6	Suction line	28
9.7	Filtration	28
9.8	Outlet line.....	29
9.9	Calculation of the internal diameter of the duct pipes	29
9.10	V-belt transmission.....	29
9.11	Transmission definition	30
9.12	Definition of static pull to apply on belts.....	32
9.13	Transmission of power from the second PTO.....	32
10	START-UP AND OPERATION	32
10.1	Preliminary checks.....	32
10.2	Start-up.....	33
11	PREVENTIVE MAINTENANCE	33
12	PUMP STORAGE	33
12.1	Long-term inactivity	33
12.2	Method for filling pump with anti-corrosion emulsion or anti-freeze solution	33
13	PRECAUTIONS AGAINST FROST.....	33
14	WARRANTY CONDITIONS.....	34
15	OPERATING FAULTS AND THEIR POSSIBLE CAUSES	34
16	EXPLODED DRAWING AND PARTS LIST.....	35
17	FLUSHING CIRCUIT DIAGRAM OF USE.....	38
18	DECLARATION OF INCORPORATION	39

1 INTRODUCTION

This manual describes the instructions for use and maintenance of the KT-KTB-W-WK LOW-PRESSURE version pump and should be carefully read and understood before using the pump.

Proper pump operation and duration depend on the correct use and maintenance.

Interpump Group disclaims any responsibility for damage caused by negligence or failure to observe the standards described in this manual.

Upon receipt, check that the pump is intact and complete. Report any faults before installing and starting the pump.

2 DESCRIPTION OF SYMBOLS

Read the contents of this manual carefully before each operation.



Warning Sign



Read the contents of this manual carefully before each operation.



Danger Sign

Danger of electrocution.



Danger Sign

Wear a protective mask.



Danger Sign

Wear protective goggles.



Danger Sign

Put on protective gloves before each operation.



Danger Sign

Wear appropriate footwear



Symbol for protection against explosion.

This defines special safety requirements for the use of the pumps in areas identified in accordance with the ATEX Directive.

When pumps are ordered in the ATEX configuration because they are going to work in areas with a potentially explosive atmosphere, you must **STRICTLY comply with the notes given under the headings marked with this symbol and the instructions in the supplementary instructions manual "ATEX EXPLOSION PROTECTION"**.

3 SAFETY

3.1 General safety warnings

Improper use of pumps and high pressure systems as well as non-compliance with installation and maintenance standards can cause serious damage to people and/or property. Anyone assembling or using high pressure systems must possess the necessary competence to do so, knowing the characteristics of the components to be assembled/used and taking all the necessary precautions to ensure maximum safety in all conditions of use. In the interest of safety, both for the Installer and the Operator, no reasonably applicable precaution should be omitted.

3.2 Essential safety in the high pressure system

1. The pressure line must always be provided with a safety valve.
2. High pressure system components, particularly for systems that operate primarily outside, must be adequately protected from rain, frost and heat.
3. The electrical control system must be adequately protected against sprays of water and must meet specific regulations in force.
4. The high pressure pipes must be properly sized for maximum operating pressure of the system and always used within the operating pressure range specified by the Manufacturer of the pipe itself. The same rules should be observed for all other auxiliary systems affected by high pressure.
5. The ends of high pressure pipes must be sheathed and secured in a solid structure, to prevent dangerous whiplash in case of bursting or broken connections.
6. Appropriate protective casing must be provided in pump transmission systems (couplings, pulleys and belts, auxiliary power outlets).

3.3 Safety during work



The room or area within which the high pressure system operates must be clearly marked and prohibited to unauthorized personnel and, wherever possible, segregated or fenced to ensure restricted access. Personnel authorized to access this area should first be instructed how to operate within this area and informed of the risks arising from high pressure system defects or malfunctions.

Before starting the system, the Operator is required to verify that:

1. The high pressure system is properly powered, see chapter 9 par. 9.5.
2. The pump suction filters are perfectly clean; it is appropriate to include a device indicating the clogging level on all devices.
3. Electrical parts are adequately protected and in perfect condition.
4. The high pressure pipes do not show signs of abrasion and the fittings are in perfect order.
5. In relation to the application, use and environmental conditions, during the operation the outer surfaces of the pump may reach high temperatures. Therefore we recommend to take precautions to avoid contact with hot parts.

Any fault or reasonable doubt that may arise before or during operation should be promptly reported and verified by qualified personnel. In these cases, pressure should be immediately cleared and the high pressure system stopped.

3.4 Rules of conduct for the use of lances



1. The operator must always place his safety and security first, as well as that of others that may be directly affected by his/her actions, or any other assessments or interests. The operator's work must be dictated by common sense and responsibility.

- The operator must always wear a helmet with a protective visor, waterproof gear and wear boots that are appropriate for use and can ensure a good grip on wet floors.

Note: *appropriate clothing will protect against sprays of water but not from direct impact with jets of water or very close sprays. Additional protections may therefore be necessary in certain circumstances.*

- It is good practice to organize personnel into teams of at least two people capable of giving mutual and immediate assistance in case of necessity and of taking turns during long and demanding operations.
- The work area jet range must be absolutely prohibited to and free from objects that, inadvertently under a pressure jet, can be damaged and/or create dangerous situations.
- The water jet must always and only be pointed in the direction of the work area, including during preliminary tests or checks.
- The operator must always pay attention to the trajectory of debris removed by the water jet. Where necessary, suitable guards must be provided by the Operator to protect anything that could become accidentally exposed.
- The operator should not be distracted for any reason during work. Workers needing to access the operating area must wait for the Operator to stop work on his/her own initiative, after which they should immediately make their presence known.
- It is important for safety that all team members are always fully aware of each other's intentions in order to avoid dangerous misunderstandings.
- The high pressure system must not be started up and run under pressure without all team members in position and without the Operator having already directed his/her lance toward the work area.

3.5 Safety during system maintenance

- High pressure system maintenance must be carried out in the time intervals set by the manufacturer who is responsible for the whole group according to law.
- Maintenance should always be performed by trained and authorized personnel.
- Assembly and disassembly of the pump and the various components must only be carried out by authorized personnel, using appropriate equipment in order to prevent damage to components, in particular to connections.
- Always only use original spare parts to ensure total reliability and safety.

4 PUMP IDENTIFICATION

Each pump has its own Serial No. XX.XXX.XXX see pos. ① and an identification plate see pos. ② in Fig. 1 which shows:

- Pump model and version
- Max revs
- Absorbed power HP - kW
- Flow rate l/min - Rpm
- Pressure bar- PSI

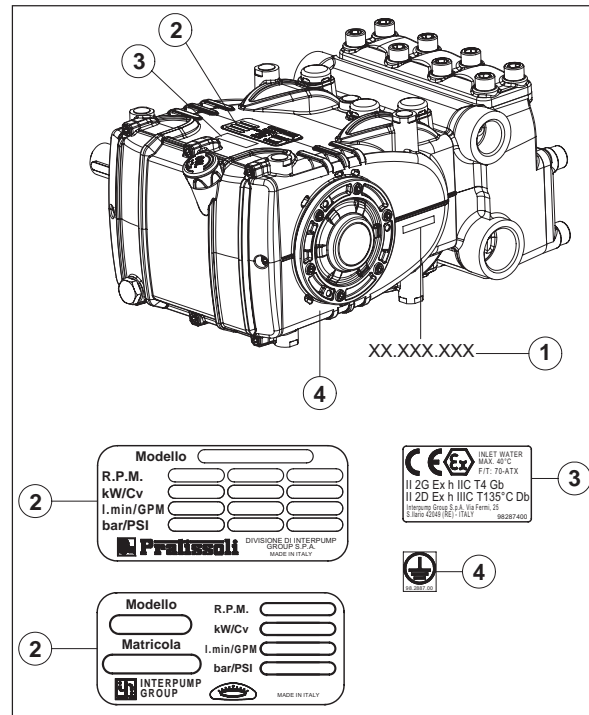

Fig. 1



For pumps ordered with the ATEX configuration. Pos. ③ plate **with specific ATEX marking for explosion protection.**

Pos. ④ plate for locating the **grounding screw.**



Model, version and serial number must always be indicated when ordering spare parts

5 TECHNICAL CHARACTERISTICS

Model	Rpm	Flow rate		Pressure		Power	
		l/min	Gpm	bar	psi	kW	HP
KT 24	1450	51.1	13.50	250	3625	24.4	33.2
	1750	61.7	16.30	200	2900	23.6	32.1
KT 26	1450	60.0	15.85	250	3625	28.7	39.0
KT 28	1450	69.6	18.40	200	2900	26.6	36.2
	1750	84.0	22.20	175	2538	28.0	38.2
KT 30	1450	79.9	21.10	175	2538	26.7	36.3
	1750	96.4	25.50	140	2030	25.8	35.1
KT 32	1450	91.0	24.0	150	2175	26.0	35.4
KT 34	1450	103.0	27.21	2175	29.4	40.0	
KT 36	1450	115.0	30.40	120	1740	26.4	35.9
	1580	125.4	33.10	125	1813	29.9	40.7
KT 40	1450	142.0	37.50	100	1450	27.0	36.9
WK155	1000	55.0	14.50	150	2175	15.74	21.4
WK 6	1000	62.0	16.40	100	1450	11.84	16.1
WK 8	1000	80.0	21.10	100	1450	15.3	20.8
KT 36B	1450	115.0	30.40	120	1740	26.4	35.9
	1580	125.4	33.10	125	1813	29.9	40.7
KT 40B	1450	142	37.50	100	1450	27.0	36.9
W 120120	1450	115.0	30.40	120	1740	26.4	35.9
W 100140	1450	142	37.5	100	1450	27.0	36.9

6 DIMENSIONS AND WEIGHT

For the dimensions and weight of pump versions KT24-KT26-KT28-KT30-KT32-WK155-WK6 refer to Fig. 2.

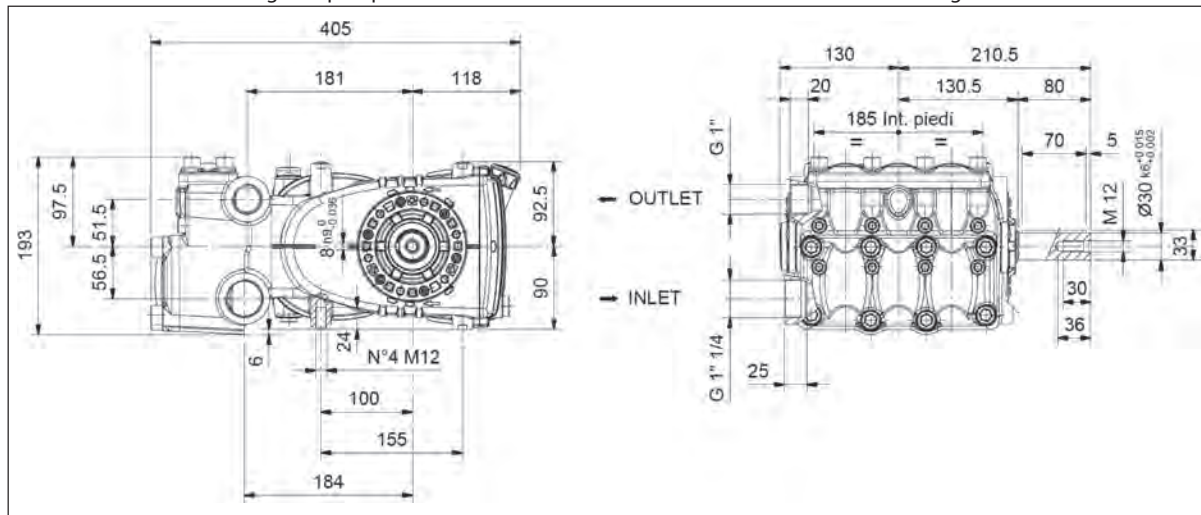

Dry weight 35 kg.

Fig. 2

For the dimensions and weight of pump versions KT34-KT36-KT40-KT36B-KT40B-W120120-W100140 refer to Fig. 2/a.

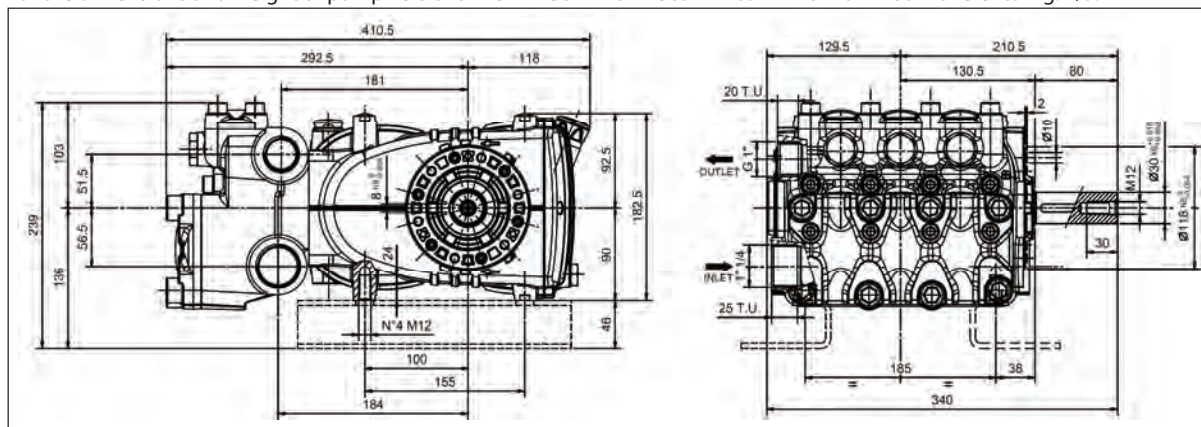

Dry weight: 37.5 Kg (KT36-KT40)

42 Kg (KT36B-KT40B-W120120-W100140)

Fig. 2/a

7 OPERATING INSTRUCTIONS



The KT-KTB-W-WK LOW-PRESSURE version pumps have been designed to operate in environments with atmospheres that are not potentially explosive, with filtered water (see par. 9.7) and at a maximum temperature of 40 °C.
Other liquids can be used only upon formal approval by the **Engineering Department** or **Customer Service Department**.

7.1 Water temperature



The maximum permissible water temperature is 40 °C. However, the pump can be used with water up to a temperature of 60 °C, but only for short periods. In this case, it is best to consult the **Technical** or **Customer Service Departments**.

7.2 Maximum pressure and flow rate

The rated specifications stated in our catalog are the max. that can be obtained by the pump. **Independently** of the power used, the maximum pressure and rpm indicated on the specification label can never be exceeded unless prior formal authorization is given by our **Technical** or **Customer Service Departments**.

7.3 Minimum operating speed

The minimum rotating speed of the pump is 100 rpm, any lower minimum speed must be expressly authorized by our **Technical** or **Customer Service Departments**.

7.4 Sound emission

The sound pressure detection test was performed according to Directive 2000/14 of the European Parliament and Council (Machinery Directive) and EN-ISO 3744-1995 with class 1 instrumentation.

A final detection of sound pressure must be performed on the complete machine/system.

Should the operator be located at a distance of less than 1 meter, he will have to use appropriate hearing protection according to current regulations.

7.5 Vibration

The detection of this value shall be carried out only with the pump set up on the plant and at the performance declared by the customer.





Values must be in accordance with regulations.

7.6 Brands and types of oils recommended

The pump is supplied with oil suitable for room temperatures from 0 °C to 30 °C.

Some types of recommended oil are indicated in the table below, these oils have additives to increase corrosion resistance and fatigue resistance (DIN 51517 part 2).

Alternatively you can also use Automotive Gear SAE 85W-90 oil for gearing lubrication.

Manufacturer	Lubricant
	AGIP ACER220
	Aral Degol BG 220
	BP Energol HLP 220
	CASTROL HYPIN VG 220 CASTROL MAGNA 220

Manufacturer	Lubricant
	Falcon CL220
	ELF POLYTELIS 220 REDUCTELF SP 220
	NUTO 220 TERESSO 220
	FINA CIRKAN 220
	RENOLIN 212 RENOLIN DTA 220
	Mobil DTE Oil BB
	Shell Tellus Öl C 220
	Wintershall Ersolon 220 Wintershall Wiolan CN 220
	RANDO HD 220
	TOTAL Cortis 220

Check the oil level and top up if necessary

Using the oil dipstick pos. ①, Fig. 3.

The correct checking of the oil level is made with the pump not running, at room temperature. The oil change must be made with the pump at working temperature, removing: the oil dipstick, pos. ①, and then the plug pos. ②, Fig. 3.

The oil check and change must be carried out as indicated in the table in Fig. 14 chapter 11.

The quantity required is ~ 2 liters.



Set up the plant so that the oil temperature does not exceed in any case **100 °C** (212 °F) during pump operation.

Use a temperature probe to be inserted into the oil drain plug pos. ② Fig. 3.

See "ATEX EXPLOSION PROTECTION" manual.

ATTENTION: Use only oil with a flash point higher than 200 °C.

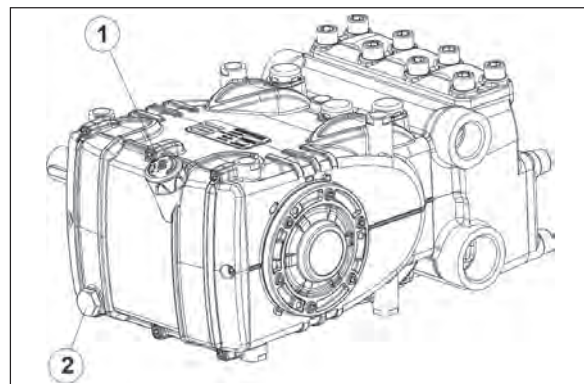

Fig. 3



In any case the oil must be changed at least once a year, as it is degraded by oxidation.

For a room temperature other than between 0 °C - 30 °C, follow the instructions in the following diagram, considering that oil must have a minimum viscosity of 180 cSt.

Viscosity / Room Temperature diagram

mm²/s = cSt

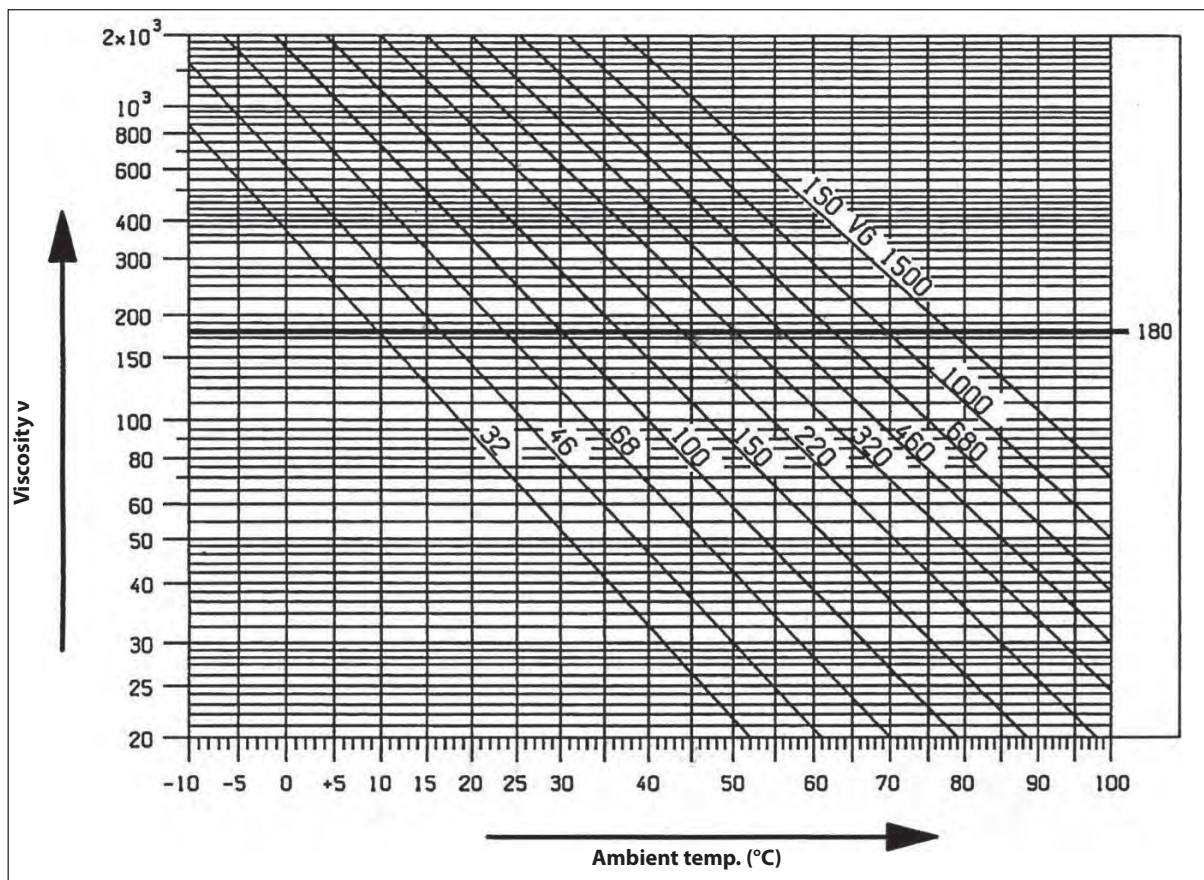

The used oil must be poured unto a suitable container and consigned to an authorized recycling center. Do not release used oil into the environment under any circumstances.

8 PORTS AND CONNECTIONS

The KT-KTB-W-WK LOW-PRESSURE version pumps (see Fig. 4) are equipped with:

- ① 2 "IN" inlet ports 1" 1/4 Gas.
Line connection to any of the two ports is indifferent for proper pump functioning. The unused ports must be hermetically closed.
- ② 2 "OUT" outlet ports 1" Gas.

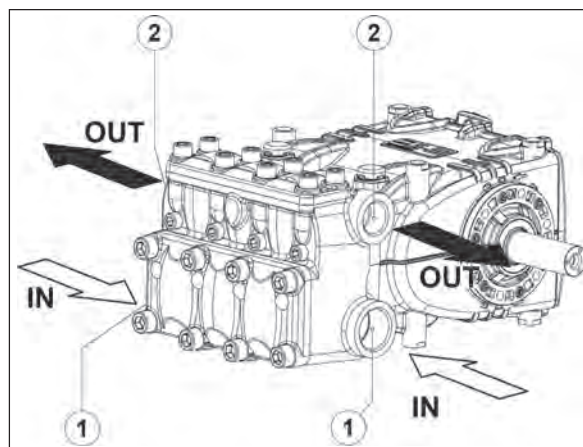

Fig. 4

9 PUMP INSTALLATION

9.1 Installation

The pump must be fixed horizontally using the M12x1.5 threaded support feet. Tighten the screws with a torque of 80 Nm.

The base must be perfectly flat and rigid enough as not to allow bending or misalignment on the pump coupling axis/transmission due to torque transmitted during operation. The unit cannot be fixed rigidly to the floor but must interposed with vibration dampers.

For special applications contact the **Technical** or **Customer Service Departments**.

An M12 threaded stud is present on the pump casing, to which an eyebolt can be applied to facilitate installation, as per the figure below.



Should it be necessary to disassemble it, to avoid the entrance of dirt in the front part of the casing, close the threaded hole with the cap provided.



Earthing: the pump must be connected to an earth conductor using the stainless steel M6 screw and stainless steel serrated washer marked with a YELLOW label. See "ATEX EXPLOSION PROTECTION" manual.



Replace the oil filling hole closing service plug (red) positioned on the rear casing cover. Check the correct quantity with the oil dipstick.

The oil dipstick must always be reachable, even when the unit is assembled.



The pump shaft (PTO) must not be rigidly connected to the drive unit.

The following types of transmission are recommended:

- Hydraulics by flange, for proper application consult with our **Technical** or **Customer Service Departments**.
- V-belts.
- Universal joint (comply with the maximum working angles recommended by the manufacturer).
- Flexible coupling.



In all cases the transmission must be assembled correctly to avoid incorrect or harsh operation of the connection parts and to prevent excessive wear, temperature rise and/or hazardous breakages that may create potential sources of ignition and explosion. See "ATEX EXPLOSION PROTECTION" manual.

9.2 Rotation direction

The rotation direction is indicated by an arrow located on the casing near the drive shaft.

From a position facing the pump head, the rotation direction will be as in Fig. 5.

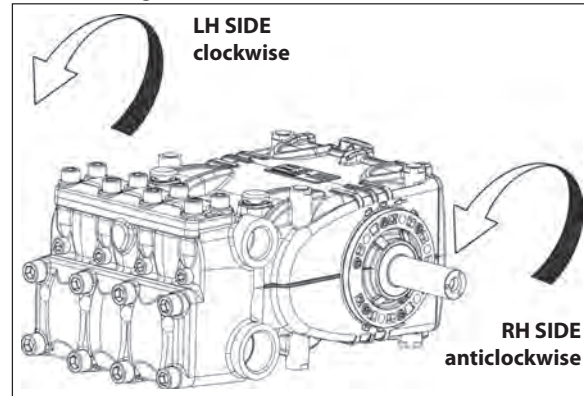

Fig. 5

9.3 Version change

The pump version is defined as right when:

Observing the pump facing the head side, the pump shaft must have a PTO shank on the right side.

The pump version is defined as left when:

Observing the pump facing the head side, the pump shaft must have a PTO shank on the left side.

Note. The version shown in Fig. 5 is right.



The version can only be modified by trained and authorized personnel and carefully following the instructions below:

1. Separate the hydraulic part from the mechanical part as indicated in chapter 2 par. 2.2.1 of the **Repair manual**.
2. Turn the mechanical part 180° and reposition the rear casing cover in such a way that the oil dipstick is turned upward. Reposition the lifting bracket and relative hole closing plugs in the upper part of the casing. Finally, properly reposition the specification label in its housing on the casing.



Make sure that the lower casing draining holes in correspondence with the pistons are open and not closed from the plastic plugs provided for the previous version.

3. Unite the hydraulic part to the mechanical part as indicated in chapter 2 par. 2.2.5 **Repair manual**.

9.4 Hydraulic connections

In order to isolate the system from vibrations produced by the pump, it is advisable to make the first section of the duct adjacent to the pump (both suction and outlet) with flexible piping. The suction hose must be sufficiently rigid to prevent deformation due to the negative pressure exerted by the action of the pump.

9.5 Pump supply

A positive head of at least 0.2 metres is required for the best volumetric efficiency.



For negative prevalence contact our *Technical or Customer Service Departments*.

9.6 Suction line

For smooth operation of the pump, the suction line must have the following characteristics:

1. Minimum internal diameter as indicated in the graph in par. 9.9 and in any case equal to or exceeding that of the pump head.



Localized restrictions should be avoided along the piping, as these can cause pressure drops resulting in cavitation. Avoid 90° elbows, connections with other piping, restrictions, reverse gradients, inverted U-curves and Tee connections.

9.7 Filtration

1 filter must be installed on the pump suction line, positioned as indicated in Fig. 6 and Fig. 6/a.

With a manually activated control valve

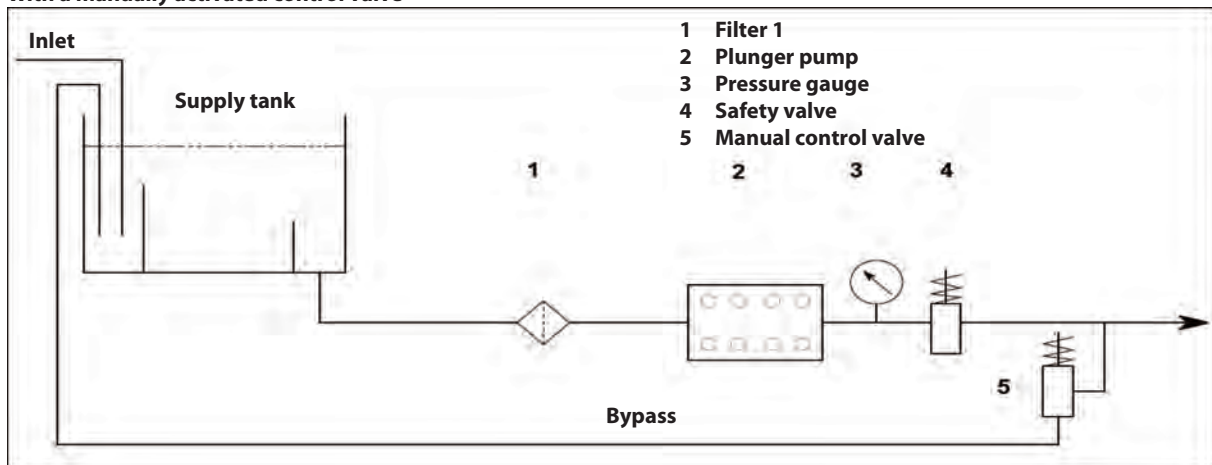

Fig. 6

With pneumatic control valve

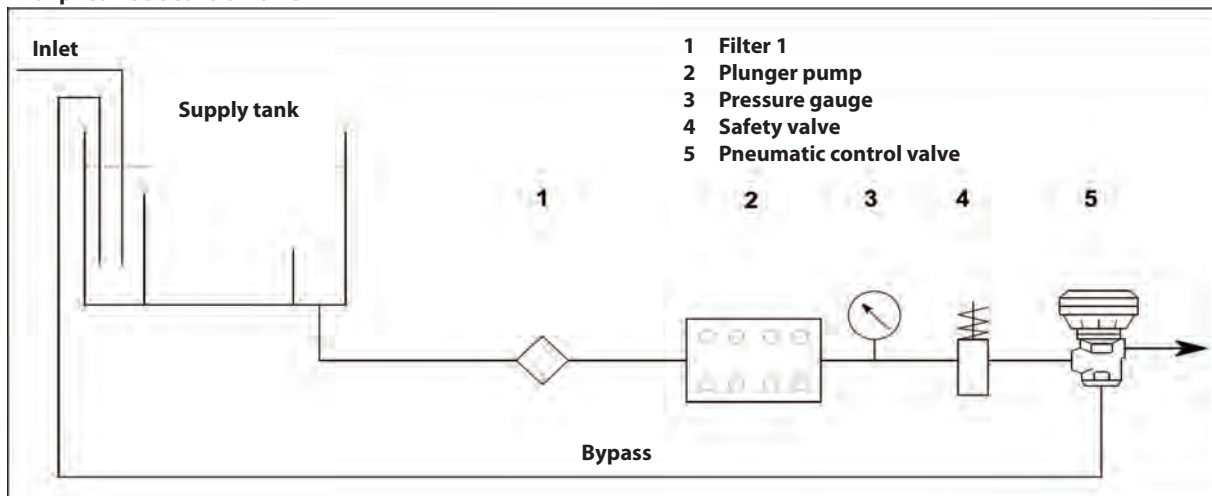

Fig. 6/a

2. The layout must be such as to prevent cavitation problems.
3. Completely airtight and constructed to ensure a perfectly hermetic seal through time.
4. Prevent the pump from emptying when it is stopped, including partial emptying.
5. Do not use 3 or 4-way hydraulic fittings, adapters, swivel joints, etc. as they could jeopardize pump performance.
6. Do not install Venturi tubes or injectors for detergent suction.
7. Avoid use of foot valves or other types of unidirectional valves.
8. Do not recirculate the by-pass valve drain directly to the suction line.
9. Provide for proper guards inside the tank to prevent that water flow from the bypass and the tank supply line can create vortices or turbulence near the pump supply pipe port.
10. Make sure the suction line is thoroughly clean inside before connecting it to the pump.

The filter, which is to be installed as close to the pump as possible, must be easily inspectable and have the following specifications:

1. Minimum flow rate at least 3 times the nominal flow rate of the pump.
2. Inlet/outlet port diameters no smaller than the inlet port diameter of the pump.
3. Filtration grade between 200 and 360 μm .



For smooth pump operation, regular filter cleaning is necessary, planned according to the actual use of the pump in relation to the quality of water used and actual clogging conditions.

9.8 Outlet line

For correct design of the outlet line comply with the following installation prescriptions:

1. The internal diameter of the pipe must be sufficient to ensure correct fluid velocity, see graph in par. 9.9.
2. The first section of the line connected to the pump outlet must be a flexible hose, in order to isolate vibration produced by the pump from the rest of the system.
3. Use high pressure pipes and fittings to ensure high safety margins in all operating conditions.
4. The outlet line must always be provided with a Max. pressure valve.
5. Use pressure gauges capable of withstanding the pulsating loads typical of plunger pumps.
6. During the design stage, keep in mind the line pressure drops that lead to a pressure reduction at the user with respect to the pressure measured on the pump.
7. For those applications where pulses produced by the pump on the outlet line may prove harmful or unwanted, install a pulsation dampener of sufficient size.

9.9 Calculation of the internal diameter of the duct pipes

To determine the internal diameter of the duct, refer to the following diagram:

Suction duct

With a flow rate of ~ 142 l/min and a water velocity of 0.5 m/sec. The graph line joining the two scales meets the central scale showing the diameters, corresponding to a value of ~ 70 mm.

Outlet duct

With a flow rate of ~ 142 l/min and a water velocity of 5.5 m/sec. The graph line joining the two scales meets the central scale showing the diameters, corresponding to a value of ~ 24 mm.

Optimal speeds:

- Suction: ≤ 0.5 m/sec.
- Outlet: ≤ 5.5 m/sec.

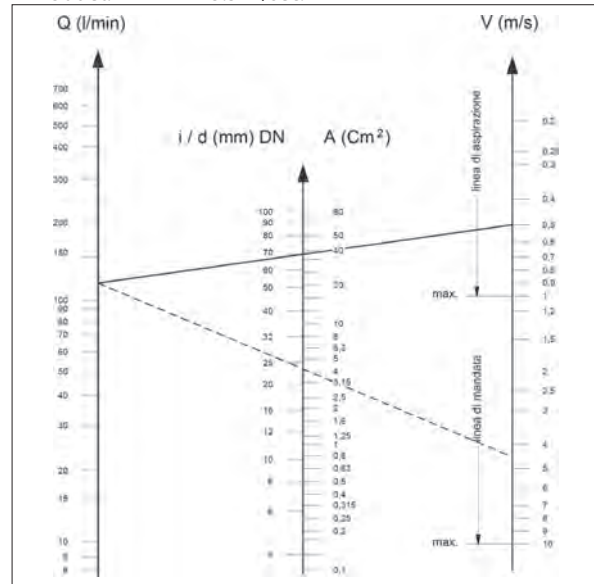

The graph does not take into account pipe resistance, valves, load loss produced by the length of the ducts, the viscosity of the liquid pumped or the temperature itself. If necessary, contact our **Technical** or **Customer Service Departments**.

9.10 V-belt transmission

The pump can be controlled by a V-belt system.

For these pump models, we recommend use of 3 XPB belts (16.5x13 serrated). Use an XPC profile only for long durations. Both the characteristics and transmissible power of each belt can be verified in the diagram in Fig. 7, in relation to the number of rpm normally declared by the manufacturer. Minimum duct pulley diameter (on pump shaft): ≥ 160 mm. The radial load on the shaft must not exceed 4500 N (value necessary for Layout definition). The transmission is considered adequate if the load is applied to a maximum distance $a = 50$ mm from the shaft shoulder (P.T.O) as shown in Fig. 10.



For dimensions differing from those specified above, contact our **Technical** or **Customer Service Departments**.

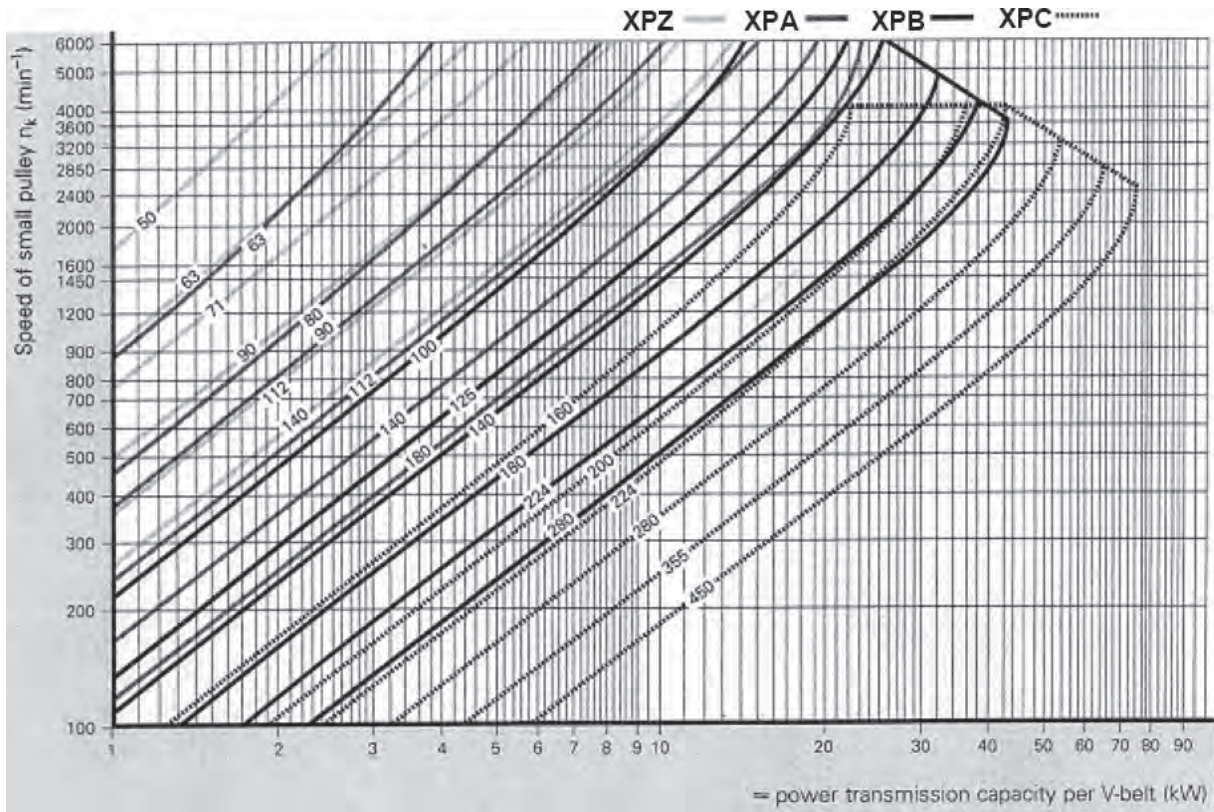

Fig. 7

9.11 Transmission definition

To prevent irregular radial loads on the shaft and the relative bearing, follow these directions:

- a) Use pulleys with V-belts with the size of the groove required/recommended by the manufacturer of belt used. In the absence of directions, follow Fig. 8 and the table in Fig. 9.

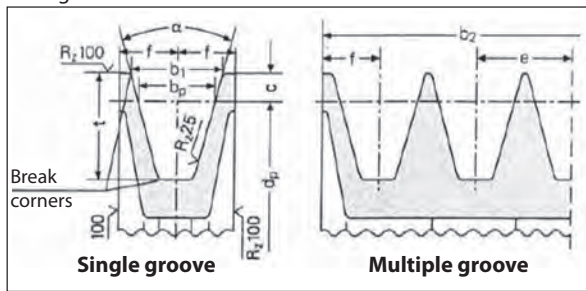

Fig. 8

Dimensions (in mm)

Belt section as per DIN 7753 part 1 and B.S. 3790		DIN symbol symbol B.S./ISO	XPB/SPB SPB	XPC/SPC SPC
Belt section as per DIN 2215 and B.S. 3790		DIN symbol symbol B.S./ISO	17 B	22 C
Pitch width		b_w	14.0	19.0
Increased grooving width $b_1 \approx$		$\alpha = 34^\circ$	18.9	26.3
		$\alpha = 38^\circ$	19.5	27.3
		c	8.0	12.0
Distance between grooving		and	23 ± 0.4	31 ± 0.5
		f	14.5 ± 0.8	20.0 ± 1.0
Increased grooving depth		t_{min}	22.5	31.5
α	34°	by primitive diameter	d_w	from 140 to 190
	38°	narrow-section V-belts DIN 7753 part 1		> 190
α	34°	by primitive diameter	d_w	from 112 to 190
	38°	classic section V-belts DIN 2215		> 190
Tolerance for $\alpha = 34^\circ\text{-}38^\circ$			$\pm 1^\circ$	$\pm 30'$
Pulleys for b_2 by grooving number z $b_2 = (z-1) e + 2 f$			1	29
			2	52
			3	75
			4	98
			5	121
			6	144
			7	167
			8	190
			9	213
			10	236
			11	259
			12	282

Minimum pulley diameter must be respected.
Do not use laminated V-belts.

Fig. 9

- b) Use high performance belts – for example **XPB** instead of **SPB** – as a lower quantity of belts for the same transmitted power may be necessary and a consequent shorter resulting distance compared to the shaft shoulder (P.T.O.) “a” of Fig. 10.

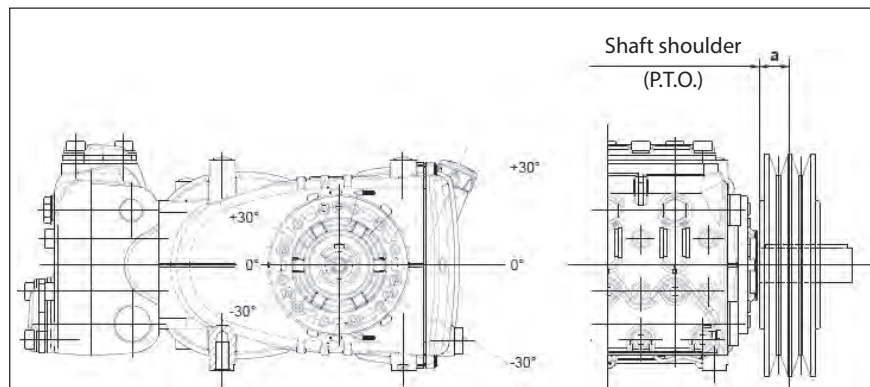

Fig. 10

- c) Pull the belts according to manufacturer instructions. Excessive pulling can cause reduced bearing life and wear out the pulley prematurely. Pulling depends on different variables as indicated in par. 9.12.
- d) Belt length has a natural tolerance $\geq \pm 0.75\%$. For this reason, the 3 belts must be purchased as a pair.
- e) Follow the direction of the belt pull as shown in Fig. 10 for other needs, contact our **Technical** or **Customer Service Departments**.
- f) Take care of the alignment of the driving pulley and driven pulley grooves.

9.12 Definition of static pull to apply on belts

Static pull depends on:

- The wheelbase between the two pulleys (belt length).
- The load due to static pull of the belt.
- The number of belts.
- The winding angle of the smallest pulley.
- Average speed.
- Etc.

Values of the static pull to be applied can be obtained from the diagram in Fig. 11 for belts with a XPB profile in relation to the wheelbase.

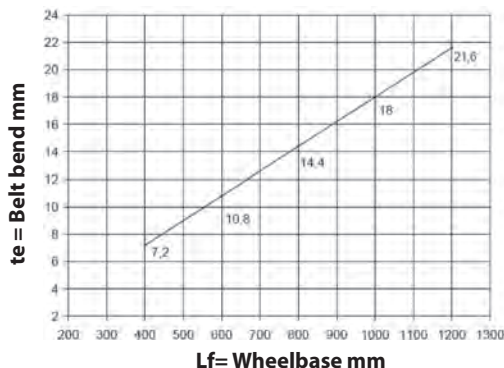
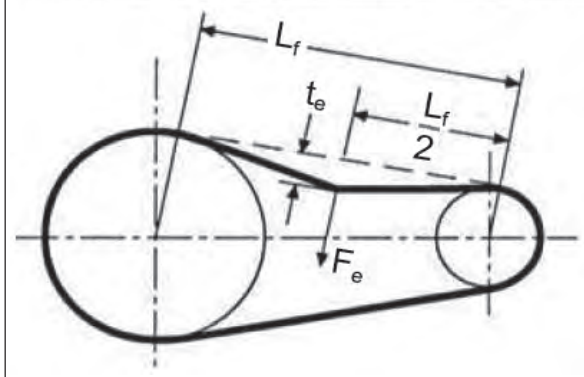
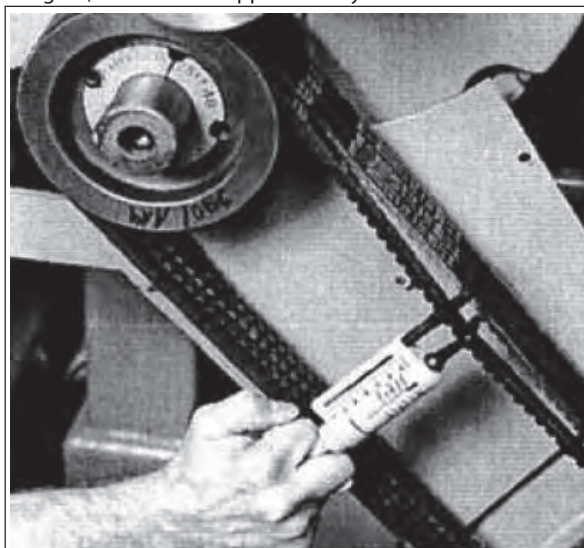

Fig. 11

Conclusion: with a wheelbase of 600 mm and with a dynamometer, loading the belt branch with 75 N as indicated in Fig. 12, a "te" bend of approximately 10.8 mm is obtained.



Lf = Wheelbase
te = Belt bend
Fe = 75 N Dynamometer load

Fig. 12

Note. Unless otherwise stated by the supplier of the belts, control of proper pull and its relative re-tensioning should be performed after no less than 30 minutes of motion necessary for the normal adjustment of the belts. Best performance and durability will be achieved with proper tensioning.

Note. In case of necessity or for routine maintenance, never replace a single belt but the complete set.

9.13 Transmission of power from the second PTO

Upon request, the KT-KTB-W-WK LOW-PRESSURE version pumps can be supplied with auxiliary PTO on the side opposite of the drive (Transmission of power from the second PTO).

Transmission can be carried out:

- By means of the V-belts.
- By means of the joint.

By means of the V-Belts, withdrawable Max Torque is: 20 Nm which corresponds to:

4.1 HP at 1450 rpm;

5.0 HP at 1750 rpm.

By means of the joint, withdrawable Max Torque is: 40 Nm which corresponds to:

8.2 HP at 1450 rpm;

10 HP at 1750 rpm.



By means of the V-belt, the transmission is considered suitable if: belt pull is applied at a max distance of 18 mm with from the bend shaft shoulder (see Fig. 13). Min diameter of pulley to be used = Ø 100 mm.



With transmission by means of the joint, pay particular attention to perfect alignment so that no transverse forces are generated on the pump shaft.

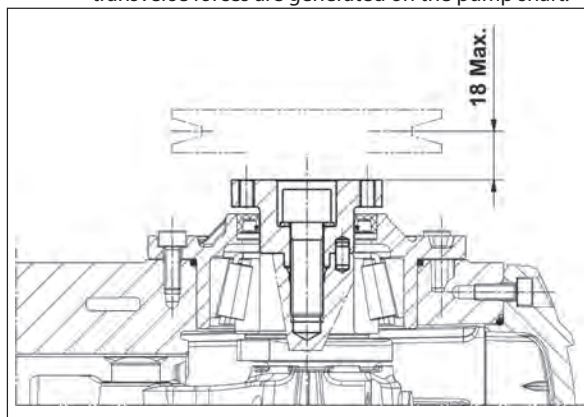

Fig. 13



For applications differing from those specified above, contact our **Technical** or **Customer Service Departments**.

10 START-UP AND OPERATION

10.1 Preliminary checks

Before start-up, ensure that:



The suction line is connected and pressurized (see par. 9.4 - 9.5 - 9.6) the pump must never run dry.

- The suction line ensures a hermetic seal over time.
- Any shut-off valves between the supply source and the pump are fully open. The outlet line is free discharge, to permit rapid expulsion of the air present in the pump manifold and therefore facilitate fast priming.
- All suction and outlet fittings and connections are properly tightened.

4. The coupling tolerances on the pump/transmission axis (half-joint misalignment, Cardan joint tilt, belt pulling, etc.) remain within limits required by the transmission manufacturer.
5. Oil in the pump casing is at level, verified with a dipstick (pos. ① Fig. 14) and exceptionally with a level indicator (pos. ② Fig. 14).

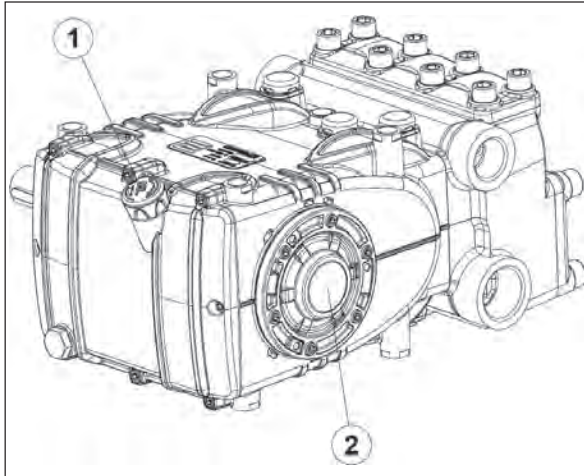

Fig. 14



In case of prolonged storage or long-term inactivity, check proper functioning of the suction and outlet valves.

10.2 Start-up

1. At first start-up, verify that the rotation direction and the supply pressure are correct.
2. Start-up the pump without any load.
3. Check that the supply pressure is correct.
4. Check that the rotation rpm during operation does not exceed the nominal rpm of the pump.
5. Let the pump run for a period of no less than 3 minutes, before putting it under pressure.
6. Before each pump stop, reset pressure by means of the control valve or with any relieving devices and reduce to a minimum rpm (activation with combustion motors).

11 PREVENTIVE MAINTENANCE

For pump reliability and efficiency, comply with maintenance intervals as shown in the table.

PREVENTIVE MAINTENANCE	
Every 500 hours	Every 1000 hours
Check oil level	Change oil
	Check / Replace: Valves Valve seats Valve springs Valve guides
	Check / Replace*: H.P. seals L.P. seals

Fig. 15



ATTENTION: Replace the bearings and the related seal rings every 2000 hours of operation.

Perform periodical checks on cleaning and maintenance on the pump. See "ATEX EXPLOSION PROTECTION" manual.

12 PUMP STORAGE

12.1 Long-term inactivity



If the pump is started for the first time after a long period from the date of shipment, before operation check the oil level, inspect the valves as specified in chapter 10, then follow described start-up procedures.

12.2 Method for filling pump with anti-corrosion emulsion or anti-freeze solution

Method for filling pump with anti-corrosion emulsion or anti-freeze solution using an external diaphragm pump based on the layout shown in par. 9.7 in Fig. 6 and Fig. 6/a:

- In place of the service tank, use a suitable container containing the solution to be pumped.
- Close the filter drainage, if open.
- Make sure that the hoses to be used are clean inside and spread grease on their connections.
- Connect the high pressure exhaust pipe to the pump.
- Connect the suction pipe to the diaphragm pump.
- Connect the suction pipe between the pump head and the diaphragm pump.
- Fill the service container with solution/emulsion.
- Insert the free ends of the suction pipes and the high pressure exhaust pipe inside the container.
- Switch on the diaphragm pump.
- Pump the emulsion until it exits from the high pressure exhaust pipe.
- Continue pumping for at least another minute.
- Stop the pump and remove the previously connected pipes.
- Clean, grease and plug the connections on the pump head.

The characteristics of the emulsion can be strengthened if necessary by adding, for example, Shell Donax.

13 PRECAUTIONS AGAINST FROST



Follow the instructions in Chapter 12 in areas and times of the year at risk of frost (see par. 12.2).



In the presence of ice, do not run the pump for any reason until the circuit has been fully defrosted, in order to avoid serious damage to the pump.

14 WARRANTY CONDITIONS

The guarantee period and conditions are contained in the purchase agreement.

The guarantee will in any case be invalidated if:

- a) The pump is used for purposes other than the agreed purposes.
- b) The pump is driven by an electric motor or internal combustion engine having performance values exceeding those shown in the table.
- c) The safety devices provided are uncalibrated or disconnected.
- d) The pump has been used with accessories or spare parts not supplied by Interpump Group.
- e) Damage has been caused by:
 - 1) improper use
 - 2) failure to follow maintenance instructions
 - 3) any use different from that described in the operating instructions
 - 4) lack of sufficient flow rate
 - 5) defective installation
 - 6) improper positioning or sizing of pipes
 - 7) unauthorized design modifications
 - 8) cavitation.

15 OPERATING FAULTS AND THEIR POSSIBLE CAUSES



The pump does not produce any noise upon start-up:

- The pump is not primed and is running dry.
- No suction water.
- Valves are jammed.
- The outlet line is closed and does not allow the release of air present in the pump manifold.



Pump pulsates irregularly:

- Air suction.
- Insufficient supply.
- Bends, elbows, fittings on the suction line are choking the passage of liquid.
- Suction filter is dirty or too small.
- The booster pump, where installed, is supplying insufficient pressure or flow rate.
- The pump is not primed due to insufficient head or the outlet is closed during priming.
- The pump is not primed due to valve jamming.
- Worn valves.
- Worn pressure seals.
- Imperfect functioning of the pressure control valve.
- Problems on the transmission.



The pump does not supply the nominal flow rate/excessive noise:

- Insufficient supply (see various causes as above).
- Pump speed is below the rated speed;
- Excessive internal leakage of pressure control valve.
- Worn valves.
- Excessive leakage from the pressure seals.
- Cavitation due to:
 - 1) Improper sizing of suction ducts/undersized diameters.
 - 2) Insufficient flow rate.
 - 3) High water temperature.



The pressure supplied by the pump is insufficient:

- The user flow (nozzle) is or has become greater than the pump capacity.
- Insufficient revolutions per minute.
- Excessive leakage from the pressure seals.
- Imperfect functioning of the pressure control valve.
- Worn valves.



Pump overheats:

- The pump is working in overpressure conditions or pump rpm is higher than the nominal value.
- Oil in the pump casing is not at level or not the recommended type as detailed in chapter 7 (see par. 7.6).
- Excess belt tension or joint or pulley alignment is incorrect.
- Excessive pump tilt during operation.



Vibrations or hammering on pipes:

- Air suction.
- Faulty operation of pressure control valve.
- Valves malfunction.
- Non-uniformity of transmission motion.

KIT RICAMBIO – SPARE KIT

		KT24 (D.24) KIT 2006	KT26 (D.26) KIT 2464	KT28 (D.28) KIT 2008	KT30 WK155 KIT 2010	KT32 WK6 KIT 2248	KT34 WK8 (D.34) KIT 2465	KT36 WK8 (D.36) KIT 2249	KT40 (D.40) KIT 2249
A	Kit tenute pompani – Plunger packing kit								
B	Kit valvole aspirazione – In valves kit	KIT 2246							
C	Kit valvole mandata – Out valves kit								
D	Kit tenute complete – Complete seals kit	KIT 2250	KIT 2466	KIT 2251	KIT 2252	KIT 2253	KIT 2467	KIT 2254	KIT 2255
E	Kit bronzine bielle – Conrod bushing kit								

KT24 KT26 KT28
KT30 KT32 KT34
KT36 KT40

WK155
WK6 - WK8

POS	CODE CODICE	DESCRIPTION DESCRIZIONE	KIT	NR. PCS.	POS	CODE CODICE	DESCRIPTION DESCRIZIONE	KIT	NR. PCS.	DESCRIPTION DESCRIZIONE	KIT	NR. PCS.	
1	70.0300.22	CARTER POMPA		1	90.2737.00	ANELLO TEN. A.L.T. D. 24.0x32.0x5.5 LP	A-D	57	70.2250.15	COPERCHIO VALVOLE D'ASPIRAZIONE		1	
2	91.8477.00	CUSCINETTO RULLI	D	2	90.2749.10	ANELLO TEN. A.L.T. D. 26.0x34.0x5.5 LP	A-D	58	99.4850.00	VITE M14x40 UNI 4762		8	
3	90.3915.00	OR D. 80.60x2.62 NBR 70SH 3318	D	2	90.2750.10	ANELLO TEN. A.L.T. D. 28.0x36.0x5.5 LP	A-D	59	99.3885.50	OR D. 45.69x2.62 NBR 90SH 3181 - KT34+40	D	3	
4	70.2200.81	SPESSORE DI RASAMENTO 0.10 mm.		1	90.2760.00	ANELLO TEN. A.L.T. D. 30.0x38.0x5.5 LP	A-D	3	90.3894.00	OR D. 53.65x2.62 NBR 90SH 3212 - KT34+40	D	3	
5	90.0755.00	ANELLO D'ARRESTO ZH45	D	1	90.2795.00	ANELLO TEN. A.L.T. D. 32.0x40.0x5.5 LP	A-D	61	36.2045.05	MOLLA Dm. 24.7x27.0 - KT34+40		3	
6	70.2118.01	SPIA LIVELLO OLIO	D	1	90.2798.00	ANELLO TEN. A.L.T. D. 34.0x42.0x5.4 LP	A-D	62	94.7540.00	MOLLA Dm. 24.7x27.0 - KT34+40		3	
7	90.3877.00	OR D. 89.36x2.62 NBR 70SH 3156	D	1	90.2828.00	ANELLO TEN. A.L.T. D. 40.0x48.0x5.4 LP	A-D	64	36.2086.51	GUIDA VALVOLA INTERNA - KT34+40		3	
8	70.1501.22	COPERCHIO CUSCINETTO LATO SPIA		1	70.2162.70	ANELLO INTERMEDIO D. 26		65	36.2116.66	SEDE VALVOLA D'ASPIRAZIONE - KT34+40		3	
9	99.1854.00	VITE M6x16 5931		20	70.2163.70	ANELLO INTERMEDIO D. 28		66	90.3880.00	OR D. 42.52x2.62 NBR 70SH 3168 - KT34+40	D	3	
10	90.3833.00	OR D. 13.95x2.62 NBR 70SH 3056	D	1	70.2164.70	ANELLO INTERMEDIO D. 30		67	90.5233.00	ANELLO ANT. D. 43.5x48.0x1.5 - KT34+40	D	3	
11	98.2100.80	TAPPO G 3/8"x13 TEZZ. - ZINC.		1	70.2252.70	ANELLO INTERMEDIO D. 32		68	36.7207.01	GR. VALVOLA D'ASPIRAZIONE - KT34+40	B	3	
12	98.2115.00	TAPPO CON ASTA D. 21.5x70.0		1	70.2281.70	ANELLO INTERMEDIO D. 34		69	36.7260.01	GR. VALVOLA DI MANDATA - KT34+40	C	3	
13	72.2106.95	TUBO PER ASTA LIVELLO OLIO		1	70.2284.70	ANELLO INTERMEDIO D. 36		71	94.7451.00	MOLLA Dm. 16.0x37.0 - KT34+40		3	
14	90.3604.00	OR D. 25.12x1.78 NBR 70SH 2100	D	1	90.2749.00	ANELLO "RESTOP" D. 24.0x35.0x5.0/2.2	A-D	100	99.0502.66	STELO GUIDA PISTONE		3	
15	70.1606.22	COPERCHIO CARTER	D	1	90.2749.60	ANELLO "RESTOP" D. 26.0x35.0x5.0/2.2	A-D	101	99.1925.00	VITE M6x35 5931		6	
16	90.3942.00	OR D. 190.17x2.62 NBR 70SH 3750	D	1	90.2758.00	ANELLO "RESTOP" D. 28.0x45.0x5.0/4.0	A-D	110	90.3528.00	OR D. 29.00x1.50 NBR 70SH	D	3	
17	98.2005.00	TAPPO PER FORO D. 15		41	90.2758.00	ANELLO "RESTOP" D. 30.0x45.0x5.0/4.5	A-D	111	99.1809.00	VITE M6x10 5931 - ATEX		1	
18	99.3123.00	VITE SERRAGGIO BIELLA	D	5	90.2784.00	ANELLO "RESTOP" D. 32.0x44.0x5.0/3.0	A-D		96.6939.50	ROSETTA D. 6.4x11.0x0.7 - ATEX		1	
19	70.0206.35	ALBERO A GOMITI C. 26		6	90.2793.00	ANELLO "RESTOP" D. 34.0x48.0x6.0/3.0	A-D		CON SISTEMA FLUSHING - FLUSHING SYSTEM				
20	91.4900.22	COPERCHIO CUSCINETTO LATO PTO	D	1	90.2818.00	ANELLO "RESTOP" D. 36.0x48.0x6.0/3.0	A-D		CON FLANGIA "A" - WITH DIRECT DRIVE FLANGE				
21	90.1668.00	ANELLO RAD. D. 35.0x52.0x7.0	D	1	90.2838.00	ANELLO "RESTOP" D. 40.0x55.0x8.0/4.5	A-D	87	99.3084.00	VITE M8x30 5931		6	
22	90.1677.00	ANELLO RAD. D. 36.0x47.0x6.0/7.5	D	3	90.2745.00	ANELLO TEN. A.L.T. D. 24.0x35.0x6.0/4.0 HP	A-D	86	10.0673.20	FLANGIA MOTORE IDR. TIPO A		1	
23	96.7099.00	PISTONE D. 28x63		3	90.2749.40	ANELLO TEN. A.L.T. D. 28.0x45.0x6.0/4.0 HP	A-D		MOTORE IDR. SAE-B - SAE-B HYDR. MOTOR DRIVE				
24	70.0421.09	PISTONE D. 28x63		1	90.2758.00	ANELLO TEN. A.L.T. D. 28.0x45.0x6.0/5.0 HP	A-D	88	99.3136.00	VITE M8x45 UNI 5931		6	
25	70.0403.09	PISTONE D. 28x63		3	90.2770.00	ANELLO TEN. A.L.T. D. 30.0x45.0x7.5/4.5 HP	A-D	89	10.0755.47	ELEMENTO ELASTICO GIUNTO DI. 46		1	
26	90.3584.00	OR D. 10.82x1.78 NBR 90SH 2043	D	3	90.2788.00	ANELLO TEN. A.L.T. D. 32.0x44.0x6.0/3.5 HP	A-D	90	10.7430.01	GIUNTO ELASTICO D. 30x25.4		1	
27	70.0241.36	VITE FISSAGGIO PISTONE		3	90.2792.00	ANELLO TEN. A.L.T. D. 34.0x48.0x6.0/3.5 HP	A-D	91	10.0752.20	FLANGIA MOTORE IDR. SAE-B		1	
28	70.0501.15	GUIDA PISTONE		3	90.2820.00	ANELLO TEN. A.L.T. D. 36.0x48.0x6.0/3.5 HP	A-D	98	98.2060.00	TAPPO PER FORO D. J5		2	
29	97.7420.00	SPINOTTO D. 18x36		3	90.2832.00	ANELLO TEN. A.L.T. D. 40.0x55.0x7.5/4.5 HP	A-D		PDF AUSILIARIA - AUXILIARY PTO				
30	90.9100.00	BOCCOLA PIEDE BIELLA		3	90.1002.51	ANELLO DI TESTA PISTONE D. 24		9	99.1854.00	VITE M6x16 5931		6	
31	90.9220.00	SEMIBOCC. TESTA BIELLA - SUP.	E	3	70.1007.51	ANELLO DI TESTA PISTONE D. 26		20	91.4900.00	LINGUETTA 8.0x7.0x70.0		1	
32	90.9223.00	SEMIBOCC. TESTA BIELLA - INF.	E	3	70.1003.51	ANELLO DI TESTA PISTONE D. 28		21	70.1500.22	COPERCHIO CUSCINETTO LATO PTO		1	
33	70.6068.01	GR. GUIDA PISTONE		43	70.1004.51	ANELLO DI TESTA PISTONE D. 30		22	90.1668.00	ANELLO RAD. D. 35.0x52.0x7.0		1	
34	70.0305.01	BIELLA COMPLETA		3	72.1000.51	ANELLO DI TESTA PISTONE D. 32		92	70.0207.35	ALBERO A GOMITI C. 26 D.PTO		1	
35	71.2259.51	CAPPUCCIO TAPPO CARTER		3	70.1008.51	ANELLO DI TESTA PISTONE D. 34		93	97.6152.00	SPINA CILINDRICA D. 5.0x10.0		1	
36	70.2225.51	TAPPO CARTER	A-D	3	71.1002.51	ANELLO DI TESTA PISTONE D. 36		94	70.2234.54	DISP. PRESA DI FORZA AUSILIARIA		1	
37	90.3626.00	OR D. 80.52x1.78 NBR 70SH 2200	A-D	3	71.1003.51	ANELLO DI TESTA PISTONE D. 40		96	99.4295.00	VITE M12x35 5931		1	
					70.2251.15	COPERCHIO VALVOLE DI MANDATA		1	MOTORE IDR. SAE-B - SAE-B HYDR. MOTOR DRIVE				
					99.4295.00	VITE M12x35 UNI 4762		6	86	99.3084.00	VITE M8x30 5931		6
					70.2253.70	TAPPO VALVOLE - KT24+32		6	103	70.0209.35	ALBERO A GOMITI C. 26 HYP SAE-B		1
					90.3865.00	OR D. 29.82x2.62 NBR 70SH 3118		6	102	10.0853.22	FLANGIA MOTORE IDR. SAE-B		1
					90.5180.00	ANELLO ANTIES. D. 32.4x36.5x1.5 - KT24+32		6	104	90.2665.00	TAPPO PER FORO D. 17		1
					36.2047.32	GUIDA VALVOLA - KT24+32		6	105	70.2267.71	ANELLO PER ALBERO D. 30 HYDR PACK		1
					94.7450.00	MOLLA Dm. 16.0x27.5 - KT24+32		6	106	70.2270.34	VITE M6x1.5 CON INCAVO COMPLETA		1
					36.2010.76	VALVOLA SFERICA - KT34+40		3	107	92.2025.00	DADO M6x5 5588		1
					36.2117.66	VALVOLA SFERICA - KT24+32		6					
					36.2048.66	SEDE VALVOLA		6					
					90.5178.00	ANELLO ANTIES. D. 31.0x35.5x1.5	B-D	6+3					
					36.7208.01	GR. VALVOLA ASP. / MANDATA - KT24+32	B-C	6					
					99.3816.00	VITE M10x10 UNI 5931	B-C	8					
					70.1264.15	TESTATA PER PISTONE D. 24+26		1					
					70.1265.15	TESTATA PER PISTONE D. 28+30							
					70.1266.15	TESTATA PER PISTONE D. 32							
					70.1261.15	TESTATA PER PISTONE D. 34+36							
					70.1262.15	TESTATA PER PISTONE D. 40							

KIT RICAMBIO – SPARE KIT

A	Kit tenute pompanti – Plunger packing kit	KT36B W120120 (D.36)	KT40B W100140 (D.40)
B	Kit valvole aspirazione – In valves kit	KIT 2133	KIT 2249
C	Kit valvole mandata – Out valves kit	KIT 2247	KIT 2391
D	Kit tenute complete – Complete seals kit	KIT 2254	KIT 2255
E	Kit bronzine bielle – Conrod bushing kit	KIT 2156	

KT36B	KT40B
W120120	W100140

POS	CODE IDR	DESCRIPTION DESCRIZIONE	KIT	NR. PCS.	POS	CODE IDR	DESCRIPTION DESCRIZIONE	KIT	NR. PCS.
1	70.0100.22	CARTER POMPA	D	1	88	99.3136.00	VITE M8x45 UNI 5931		6
2	91.8477.00	CUSCINETTO RULLI	D	2	89	10.0755.47	ELEMENTO ELASTICO GIUNTO DI. 46		1
3	90.3915.00	OR D. 80.60x2.62 NBR 70SH 3318	D	2	90	10.7430.01	GIUNTO ELASTICO D. 30.0x25.4		1
4	70.2200.81	SPESSORE DI RASAMENTO 0.10 mm.		1	91	10.0752.20	FLANGIA MOTORE IDR. SAE-B		1
	70.2203.81	SPESSORE DI RASAMENTO 0.25 mm.		1	98	98.2060.00	TAPPO PER FORO D. 15		2
5	90.0756.00	ANELLO D'ARRESTO J45	D	1	PDF AUSILIARIA – AUXILIARY PTO				
6	70.2118.01	SPIA LIVELLO OLIO		1	9	99.1854.00	VITE M6x16 5931		6
7	90.3877.00	OR D. 39.34x2.62 NBR 70SH 3156	D	1	20	91.4900.00	LINGUETTA 8.0x7.0x70.0		1
8	70.1501.22	COOPERCHIO CUSCINETTO LATO SPIA	D	1	21	70.1500.22	COOPERCHIO CUSCINETTO LATO PTO		1
9	99.1854.00	VITE M6x16 5931		20	3	90.1668.00	ANELLO RAD. D. 35.0x52.0x7.0		1
10	90.3833.00	OR D. 43.95x2.62 NBR 70SH 3056	D	1	3	70.0207.35	ALBERO A GOMITI C. 26 D.P.TO		1
11	98.2100.50	TAPPO G 3/8"x13 TE22 - ZINC.		1	92	90.0207.35	ALBERO A GOMITI C. 26 D.P.TO		1
12	98.2115.00	TAPPO CON ASTA D. 21.5x70.0		1	93	97.6152.00	SPIA CILINDRICA D. 5.0x10.0		1
13	72.2106.95	TUBO PER ASTA LIVELLO OLIO		1	94	70.2234.54	DISP. PRESA DI FORZA AUSILIARIA		1
14	90.3604.00	OR D. 25.12x1.78 NBR 70SH 2100	D	1	95	96.7160.00	ROSETTA D. 12.0x18.0x1.0		1
15	70.1606.22	COOPERCHIO CARTER	D	1	96	99.4295.00	VITE M12x35 5931		1
16	90.3942.00	OR D. 190.17x2.62 NBR 70SH 3750	D	1	MOTORE IDR. SAE-B – SAE-B HYDR. MOTOR DRIVE				
17	98.2005.00	TAPPO PER FORO D. 15		5	86	99.3084.00	VITE M8x30 5931		6
18	99.3123.00	VITE SERRAGGIO BIELLA		6	102	70.0209.35	ALBERO A GOMITI C. 26 HYP SAE-B		1
19	70.0206.35	ALBERO A GOMITI C. 26		1	103	10.0853.22	FLANGIA MOTORE IDR. SAE-B		1
20	91.4900.00	LINGUETTA 8.0x7.0x70.0		1	104	90.2065.00	TAPPO PER FORO D. 17		1
21	70.1500.22	COOPERCHIO CUSCINETTO LATO PTO		1	105	70.2267.71	ANELLO PER ALBERO D. 30 HYDR-PACK		1
22	90.1668.00	ANELLO RAD. D. 35.0x52.0x7.0		1	106	70.2270.34	VITE M6x12 CON INCAVO COMPLETA		1
23	90.1677.00	ANELLO RAD. D. 36.0x47.0x6.0/7.5	D	3	107	92.2025.00	DADO M6x5 5588		1
24	96.7099.00	ROSETTA D. 10.0x45.0x1.0	D	3	MOTORE IDR. SAE-B – SAE-B HYDR. MOTOR DRIVE				
25	70.0405.09	PISTONE D. 36x63		3	86	99.3084.00	VITE M8x30 5931		6
	70.0412.09	PISTONE D. 40x63		3	102	70.0209.35	ALBERO A GOMITI C. 26 HYP SAE-B		1
26	90.3584.00	OR D. 10.82x1.78 NBR 90SH 2043	D	3	103	10.0853.22	FLANGIA MOTORE IDR. SAE-B		1
27	70.2241.36	VITE FISSAGGIO PISTONE		3	104	90.2065.00	TAPPO PER FORO D. 17		1
28	70.0501.15	GUIDA PISTONE		3	105	70.2267.71	ANELLO PER ALBERO D. 30 HYDR-PACK		1
29	97.7420.00	SPINOTTO D. 18x36		3	106	70.2270.34	VITE M6x12 CON INCAVO COMPLETA		1
30	90.9100.00	BOCCOLA PIEDE BIELLA		3	107	92.2025.00	DADO M6x5 5588		1
31	90.9220.00	SEMIBOCCOLA TESTA BIELLA - SUP.	E	3	CON SISTEMA FLUSHING - FLUSHING SYSTEM				
32	90.9223.00	SEMIBOCCOLA TESTA BIELLA - INF.	E	3	97	-	TESTATA POMPA - FLUSHING		1
33	70.6068.01	GR. GUIDA PISTONE		3	CON FLANGIA "A" – WITH DIRECT DRIVE FLANGE				
34	70.0305.01	BIELLA COMPLETA		3	86	99.3084.00	VITE M8x30 5931		6
35	71.2259.51	CAPPUCCIO TAPPO CARTER		3	87	10.0673.20	FLANGIA MOTORE IDR. TIPO A		1
36	70.2225.51	TAPPO CARTER		6	CON SISTEMA FLUSHING - FLUSHING SYSTEM				
37	90.3626.00	OR D. 50.52x1.78 NBR 70SH 2200	A-D	3	97	-	TESTATA POMPA - FLUSHING		1
	70.0812.70	ANELLO DI FONDO D. 36		3	CON FLANGIA "A" – WITH DIRECT DRIVE FLANGE				
38	70.0821.70	ANELLO DI FONDO D. 40		3	86	99.3084.00	VITE M8x30 5931		6
39	90.2798.00	ANELLO TEN. ALT. D. 36.0x44.0x5.5 LP	A-D	3	87	10.0673.20	FLANGIA MOTORE IDR. TIPO A		1
40	90.2828.00	ANELLO TEN. ALT. D. 40.0x48.0x5.5 LP	A-D	3	CON SISTEMA FLUSHING - FLUSHING SYSTEM				
	70.2224.70	ANELLO INTERMEDIO D. 36		3	CON FLANGIA "A" – WITH DIRECT DRIVE FLANGE				
	70.2249.70	ANELLO INTERMEDIO D. 40		3	86	99.3084.00	VITE M8x30 5931		6
				3	87	10.0673.20	FLANGIA MOTORE IDR. TIPO A		1

17 FLUSHING CIRCUIT DIAGRAM OF USE

Adhere to the following values for proper system operation:
 minimum circuit flow rate 4 l/min, maximum fluid pressure 6 bar

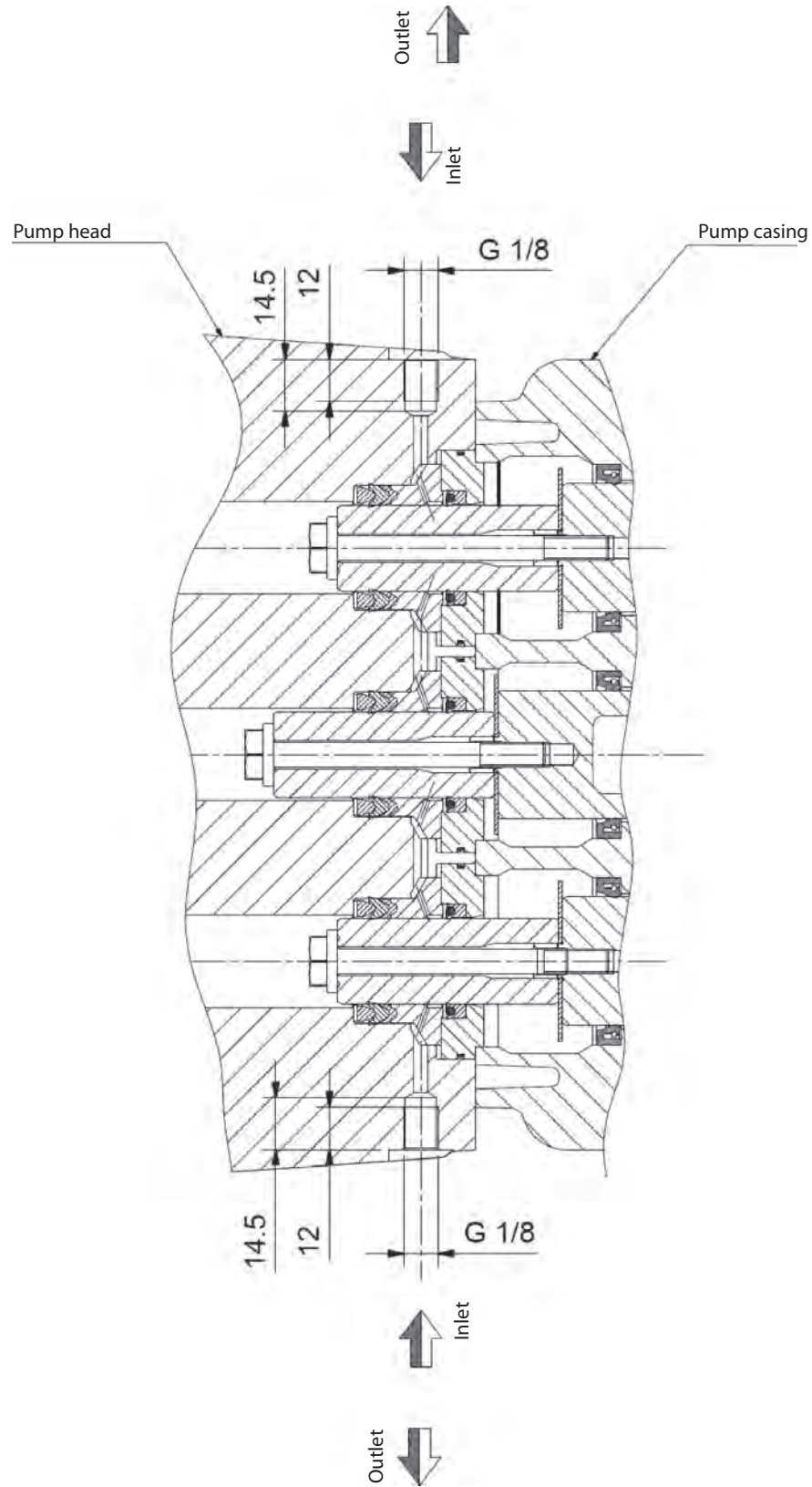

18 DECLARATION OF INCORPORATION

DECLARATION OF INCORPORATION

(In accordance with Annex II of European Directive 2006/42/EC)

The manufacturer **INTERPUMP GROUP S.p.A. - Via E. Fermi, 25 - 42049 - S. ILARIO D'ENZA - Italy** **DECLARES** that the product identified and described as follows:

Designation: Pump
Type: Reciprocating plunger pump for high pressure water
Trademark: INTERPUMP GROUP
Model: KT24-KT26- KT28-KT30-KT32-KT34-KT36-KT40-KT36B-KT40B-WK155-WK6-WK8-W120120-W100140 series

Is found to comply with the Machinery Directive 2006/42/EC
Standards applied: UNI EN ISO 12100:2010 - UNI EN 809:2000

The pump identified above meets all the essential safety and health protection requirements as listed in section 1 of Annex I of the Machinery Directive:

1.1.1 – 1.1.2 – 1.1.3 – 1.1.5 – 1.1.6 - 1.3.1 – 1.3.2 – 1.3.3 – 1.3.4 – 1.5.4 – 1.5.5 – 1.6.1 – 1.7.1 – 1.7.2 – 1.7.4 – 1.7.4.1 – 1.7.4.2 and the relevant technical documentation has been compiled in accordance with Annex VII B.

In addition, following a motivated request the manufacturer undertakes to provide a copy of the relevant pump technical documentation in the manner and terms to be defined.

The pump must not be commissioned until the plant in which it is to be incorporated has been declared in to be in compliance with the provisions of the relevant directives and/or standards.

Person authorized to compile the technical file

Name: Maurizio Novelli

Address: INTERPUMP GROUP S.p.A. - Via E. Fermi, 25 -
42049 - S. ILARIO D'ENZA (RE) - Italy

The manager:

Reggio Emilia - January 2017

Ing. Massimiliano Bizzarri

